

DOUBLE FLANGED BUTTERFLY VALVE F 012-K1



Double flanged butterfly valve with short construction length to be used in heavy duty applications.

TECHNICAL DATA

Nominal diameter:	DN 150 – DN 1200 bigger sizes upon request
Face-to-face:	EN 558 Series 20 (DIN 3202 T3 K1) ISO 5752 Series 20 (DIN 3202 T3 K1) API 609 Table 1 NF E 29-305.1
Flange accommodation:	DIN 2501 PN 6/10/16 ANSI B 16.5, Class 150 MSS SP44 Class 150 AWWA C 207 AS 2129 Table D and E BS 10 Table D and E JIS B 2211-5 K JIS B 2212-10 K
Flange Surface Design:	DIN 2526, Form A-E, ANSI RF
Top flange:	EN ISO 5211 NF E 29-402
Marking:	DIN EN 19
Tightness check:	DIN 3230 T3 BO, BN (Leakage Rate 1) ISO 5208, Category 3 API 598 Table 5 ANSI B 16-104, Class VI
Temperature range:	-20 °C to + 160 °C (depending on pressure, medium and material)
Operating pressure:	max. 16 bar
Differential pressure:	max. Δp 16 bar
Vacuum:	0,2 bar absolute (depending on medium and temperature)

FEATURES

- Absolutely tight sealing with flow in either direction
- The valve body and disc are accurately machined which results in low operating torque and long service life and reliability.
- Triple shaft bearings prevents shaft deflection and guarantees optimum guidance even after many years of operating service.
- Can be disassembled, material-specific recycling possible.
- Single flange mounting is possible.
- Can be installed in any desired position.
- Maintenance-free
- Fully repairable valve

GENERAL APPLICATIONS

- Offshore
- Water and wastewater technology
- Shipbuilding
- Power plants



DOUBLE FLANGED BUTTERFLY VALVE F 012-K1

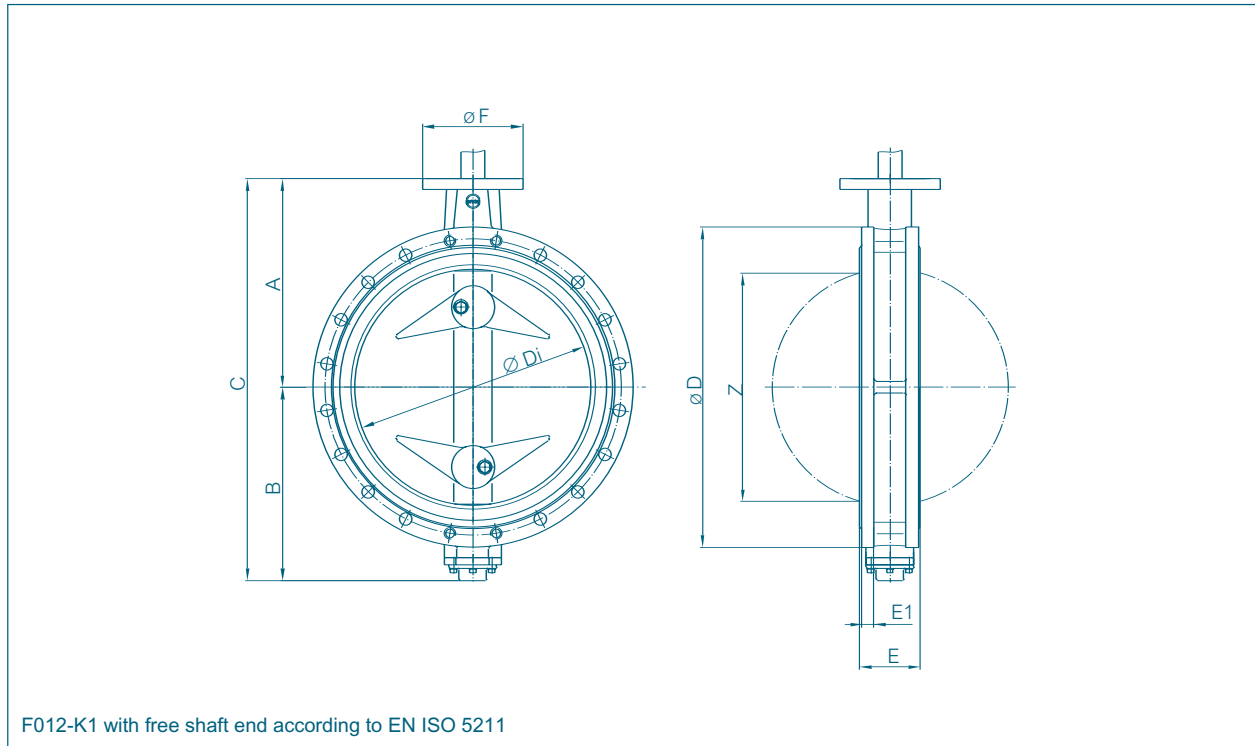

DN [mm]	Size [in]	Dimensions [mm]									Weight [kg] GGG 40	
		A	B	C	D	Di	E	F	Flansch	Z	splitted shaft	TS- shaft
150	6	203	150	353	305	148	56	90	F 07	139	22	23
200	8	228	176	404	350	199	60	90	F 07	190	32	34
250	10	266	212	478	430	248	68	125	F 10	240	47	50
300	12	291	237	528	480	296	78	125	F 10	287	69	72
350	14	332	269	601	540	338	92	150	F 12	330	80	86
400	16	363	314	677	605	388	102	150	F 12	378	120	128
450	18	397	335	732	675	430	114	210	F 16	417	144	150
500	20	437	405	842	710	494,5	127	210	F 14/F 16	474	163	170
600	24	498	469	967	830	590	154	300	F 16/F 25	563	233	260
700	28	581	507	1088	905	680	165	300	F 16/F 25	660	292	345
800	32	630	556	1186	1020	780	190	300	F 25	757	446	466
900	36	696	617	1313	1120	880	203	300	F 25	860	568	610
1000	40	771	675	1446	1250	980	216	350	F 30	956	624	722
1200	48	905	810	1715	1480	1170	254	350	F 30	1154	–	980

Subject to change without notice.

ACTUATORS TYP F 012-K1

HAND LEVER

DN [mm]	Size [in]	Hand Lever	F	H	L	Weight [kg]
150-200	6-8	Size III	90	100	276	0,50

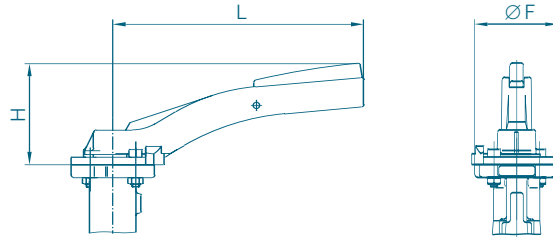

WORM GEAR

DN [mm]	Size [in]	Gear	H	J	K	L	Weight [kg]
150-200	6-8	Size III	129	47	200	202	2,3
250	10	Size IV	129	60	200	252	2,8
300-350	12-14	Size V	158	76	250	280	6,3
400-450	16-18	Size VI	228	90	356	322	16,0
500	20	Size VII	278	123	457	406	30,5
550-600	22-24	Size VIII	355	154	610	466	45,0
700-800	28-32	Size XIV	295	54	457	466	65,0
900	36	Size XV	294	97	457	498	104,0
1000	40	Size XVI	253	237	356	558	186,0
1200	48	Size XVII	323	292	457	647	262,0

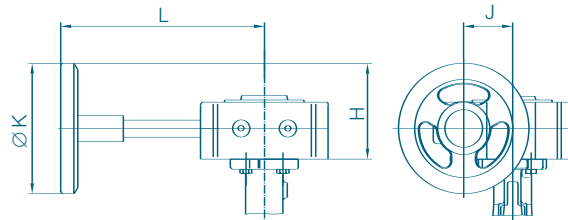

The dimensioning of actuators refers to an operating pressure of 10 bar.

ELECTRIC ACTUATOR

DN [mm]	Size [in]	Weight [kg]	H	J	K	L	M	Weight [kg]
150	2-6	E 65	233	172	80	139	119	7,0
200-250	8-10	E 110	251	245	125	139	134	14,0
300-350	12-14	E 160	239	279	198	139	157	25,0
400-500	16-20	E 210	276	369	315	139	215	40,0

The dimensioning of actuators refers to an operating pressure of 10 bar.

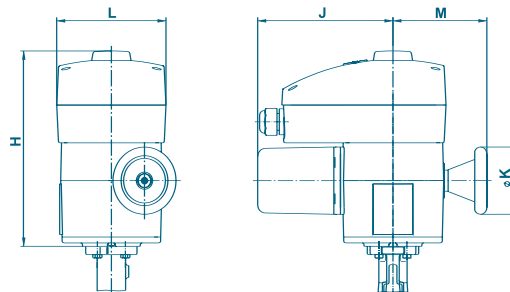

Other Actuators: See Documentation of the Manufacturer.

Subject to change without notice.

ACTUATORS TYP F 012-K1

PNEUMATIC DOUBLE ACTING

DN [mm]	Size [in]	Actuator Type	H	J	K	L	Weight [kg]
150	6	EB6	123	103	62	208	2,6
200	8	EB8	136	115	68	250	4,3
250-300	10-12	EB10	155	135	79	312	6,8
350-450	14-18	EB12	182	159	94	367	12,0
500	20	EB265	232	152	76	390	18,0
600-700	24-28	EB270	278	220	110	445	32,0
800-900	32-36	EB280	278	220	110	600	42,0

The dimensioning of actuators refers to the following operating conditions:
 Control air Pressure: 6 bar
 Operating Pressure: DN 150 - DN 300 10 bar
 DN 350 6 bar
 DN 400 - DN 900 3 bar
 Dimensioning for other conditions: upon request

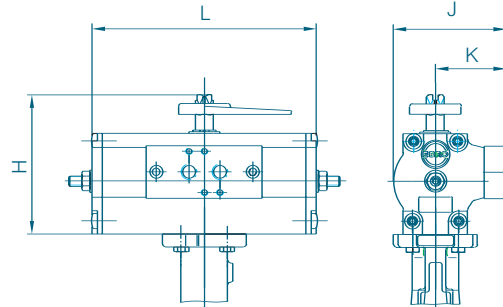

PNEUMATIC SPRING RETURN

DN [mm]	Size [in]	EBF Actuator	H	J	K	L	Weight [kg]
150	6	EB8	136	115	68	389	7,7
200	8	EB10	155	135	79	526	14,3
250-300	10-12	EB12	182	159	94	658	25,4
350-400	14-16	EB270	278	220	110	655	45,0
450-600	18-24	EB280	278	220	110	1020	68,0

The dimensioning of actuators refers to the following operating conditions:
 Control air Pressure: 6 bar
 Operating Pressure: DN 150 - DN 300 10 bar
 DN 350 6 bar
 DN 400 - DN 900 3 bar
 Dimensioning for other conditions: upon request

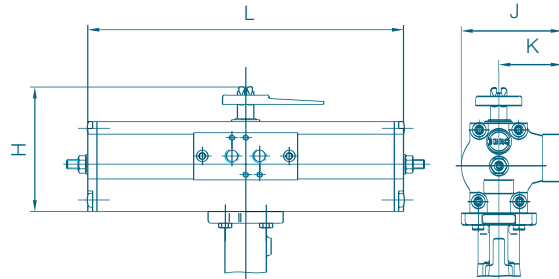

SWITCH BOX SERIES MSK/NSK

MSK: Switch Box with integrated micro limit switches.
 NSK: Switch Box with integrated proximity switches.

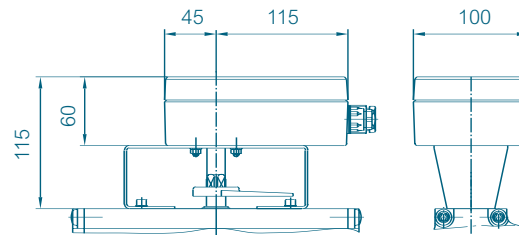

Other Actuators: See Documentation of the Manufacturer.

Subject to change without notice.

DOUBLE FLANGED BUTTERFLY VALVE F 012-K1

MATERIAL SPECIFICATION AND PARTS LIST

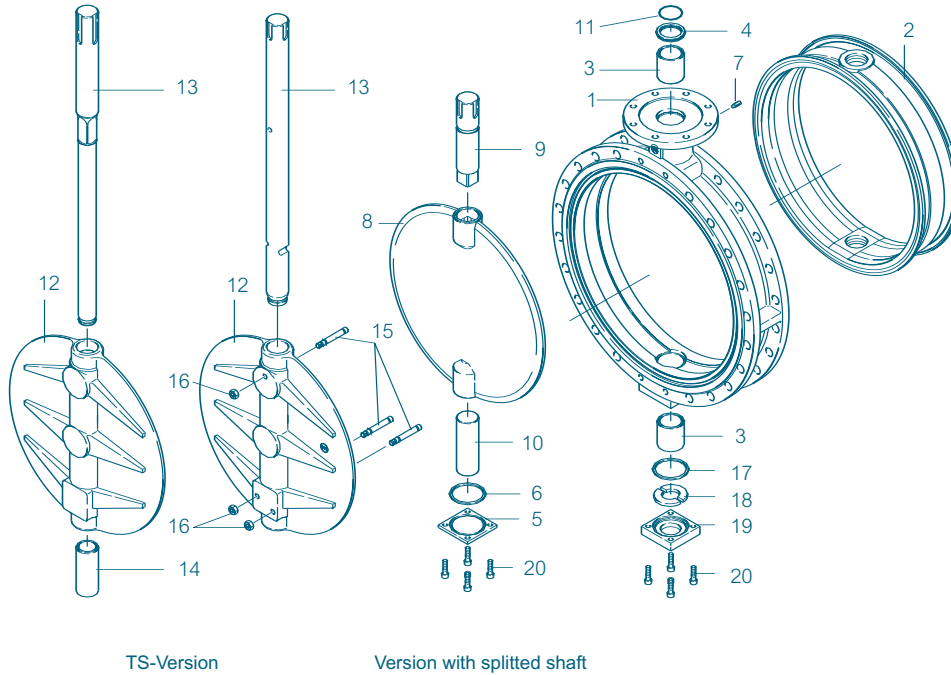

Pt.	Description	Material	Material No.	ASTM	Pt.	Description	Material	Material No.	ASTM
1	Body				9/10	Shaft			
	Nodular Cast Iron	GGG-40	0.7040	60-40-18		Stainless Steel	X14CrMoS17	1.4104	430F
2	Seal						X5CrNiMo17-12-2	1.4401	316
	NBR	Acrylonitrile butadiene rubber					Hastelloy	2.4883	Hastelloy
	EPDM	Ethylene propylene caoutchouc				Bronze	CuAlNiBZ	2.0975	
	CSM	Chlorsulphonated polyethylene			11	O-ring			
	FPM	Fluorocarbon caoutchouc				NBR	Acrylonitrile butadiene rubber		
	VSI	Silicon rubber				FPM	Fluorocarbon caoutchouc		
3/4	Bearing sleeve				12	TS-disc			
	Bronze	RG 5				Nodular Cast Iron	GGG 40	0.7040	60-40-18
	Polyamide					Stainless Steel	G-X5CrNiMo19-11-2	1.4408	A351CF8M
	PTFE					Aluminium Bronze	CuAl10Ni	2.0975	C 95800
5	Cover plate					Coating	Halar, Rilsan		
	Grey Cast Iron	GG 25	0.6025	40 B		Surface			
6	O-ring					Quality	electropolished, mirror finished		
	NBR	Acrylonitrile butadiene rubber			13	TS-shaft			
	FPM	Fluorocarbon caoutchouc				Stainless Steel	X14CrMoS17	1.4104	430F
7	Set screw DIN 915						X39CrMo17-1	1.4122	
	Steel	45 H galvanized					X5CrNiMo17-12-2	1.4401	316
	Stainless Steel	X5CrNiMo 17-12-2	1.4401	B8M		Bronze	CuAlNiBZ	2.0975	
8	Disc				14	Sleeve			
	Steel	St52.3	1.0570	572-50		Stainless Steel	X5CrNi18-10	1.4301	304
	Stainless Steel	X5CrNi 18-10	1.4301	304					
		G-X5CrNiMo19-11-2	1.4408	A 351 CF8M	15	Taper Pin			
		X2CrNiMo17-12-2	1.4404	316 I		Stainless Steel	X6CrNiMoTi17-12-2	1.4571	316Ti
		X2CrNiMoTi17-12-2	1.4571	316 TI					
		X2CrNiMoN22-5-3	1.4462	F 51	16	Hex. Nut			
		Hastelloy	2.4883	Hastelloy		Stainless Steel	A2		8
					17	O-ring			
						NBR	Acrylonitrile butadiene rubber		
	Aluminium Bronze	CuAl10Ni	2.0975	C 95800	18	Shaft retainer			
	Coating	Halar, Rilsan				Bronze	RG 5		B45
	Surface				19	Cover plate			
	Quality	electropolished, mirror finished				Grey Cast Iron	GG 25	0.6025	40 B
					20	Screw			
						Steel	45 H galvanized		
						Stainless Steel	A2-70		B8
							A4-70		B8M
	Other materials upon request.								

Subject to change without notice.

DOUBLE FLANGED BUTTERFLY VALVE F 012-K1

TORQUE

- The torque values specified (MD) are based on liquid and lubricant media.
 - Powdery (non-lubricant) media
Md x 1,3
 - Dry gases/high viscous media
Md x 1,2
 - The values specified are based on the initial breakaway torque.
 - Dynamic torque specification available upon request.
- Regarding the dimensioning of actuators, please contact our engineers.

DN [mm]	Size [in]	Operating Pressure			
		3 [bar]	6 [bar]	10 [bar]	16 [bar]
150	6	36	45	110	125
200	8	59	76	140	200
250	10	150	180	200	240
300	12	200	240	280	360
350	14	350	540	610	700
400	16	420	620	750	850
450	18	720	746	860	1500
500	20	900	1100	2255	3690
600	24	1050	2100	3000	5830
700	28	1560	2240	3450	8100
800	32	2070	3800	6600	11 200
900	36	2700	4900	7100	14 500
1000	40	4600	6780	11 500	24 400
1200	48	7800	12 000	21 000	44 000

Alle Angaben in Nm

K_V-VALUES

- The K_V-value (m³per hour) is the flow of water at a temperature of 5 °C to 30 °C (41°F to 86°F) at Δp of 1 bar.
 - The K_V-values specified are based on tests carried out by the Delfter Hydraulics Laboratories, the Netherlands.
 - Permissible velocity of flow
V_{max} 4,5 m/s for liquids and
V_{max} 70 m/s for gases.
 - The throttle function is linear at an angle 30° to 70°.
 - Avoid cavitation!
- For further values, please contact our engineers.

DN [mm]	Size [in]	Opening angel α°							
		20°	30°	40°	50°	60°	70°	80°	90°
150	6	35	90	200	360	640	900	1350	2100
200	8	43	180	350	580	1000	1600	3000	4000
250	10	125	360	660	1100	1800	3100	5300	6400
300	12	200	550	1000	1600	2600	5000	7500	8500
350	14	350	780	1400	2400	4000	8000	10 800	11 500
400	16	490	1050	1800	3100	5500	11 000	12 000	14 500
450	18	510	1080	2040	3350	6100	11 500	14 600	20 500
500	20	520	1100	2200	3500	6200	12 000	15 100	21 000
600	24	750	1400	2800	5100	8800	14 000	22 000	29 300
700	28	770	1755	3260	5980	10 600	17 100	25 300	36 000
800	32	1200	2260	4550	8230	12 900	20 300	29 300	44 600
900	36	1540	2280	6030	10 500	17 600	29 200	42 150	59 000
1000	40	2200	3970	8300	14 480	24 000	37 100	60 300	81 500
1200	48	5050	7900	13 800	19 700	33 500	53 300	73 050	102 650

Subject to change without notice.



V&A

www.valve.co.za

Johannesburg Tel : 011-397 2833
 Fax : 011-397 4700
 E-mail : sales.jhb@valve.co.za
 Durban Tel : 031-579 2593
 Fax : 031-579 2562
 E-mail : sales@valve.co.za