

WAFER TYPE BUTTERFLY VALVE Z 411-A



Resilient seated, centrally mounted wafer type valve with reduced inside diameter for PE/PP piping systems

TECHNICAL DATA

Nominal diameter:	da 50 (DN 40) - da 630 (DN 600) (SDR 11) da 50 (DN 40) - da 500 (DN 500) (SDR 17/ SDR17,6 / SDR 33)
Face-to-face:	EN 558 Series 20 (DIN 3202 T3 K1) ISO 5752 Series 20 API 609 Table 1 BS 5155 Series 4 NF E 29-305.1
Flange accommodation:	DIN 2501 PN 10
Top flange:	EN ISO 5211
Marking:	DIN EN 19
Tightness check:	DIN 3230 T3 BO, BN (Leakage Rate 1)
Temperature range:	-10 °C to +160 °C (depending on pressure, medium and material)
Operating pressure:	max. 10 bar SDR 11,0 (PE-80) max. 10 bar SDR 17,0 (PE-100) max. 6 bar SDR 17,6 (PE-80) max. 5 bar SDR 33,0 (PE-100)
Vacuum:	0,2 bar absolute (depending on medium and temperature)

FEATURES

- Conformist butterfly valve for PE/PP piping systems.
- The disc diameter corresponds to the inside diameter of PE HD and PP pressure pipes. (SDR 11/SDR 17/SDR 17,6/SDR 33)
- Short stubs must not be removed by boring. The plant reliability will not be reduced.
- There is no need to manufacture and install complicated spacers.
- Can be mounted in any desired position.
- Triple shaft bearings prevent shaft deflection and guarantee optimum guidance even after many years of operational service.
- Interchangeable seat
- Maintenance-free
- Can be disassembled, material-specific recycling possible.
- For max. pressure, a through-going shaft (TS) is mounted for sizes da 400.

GENERAL APPLICATIONS

Where PE/PP pipes are used.

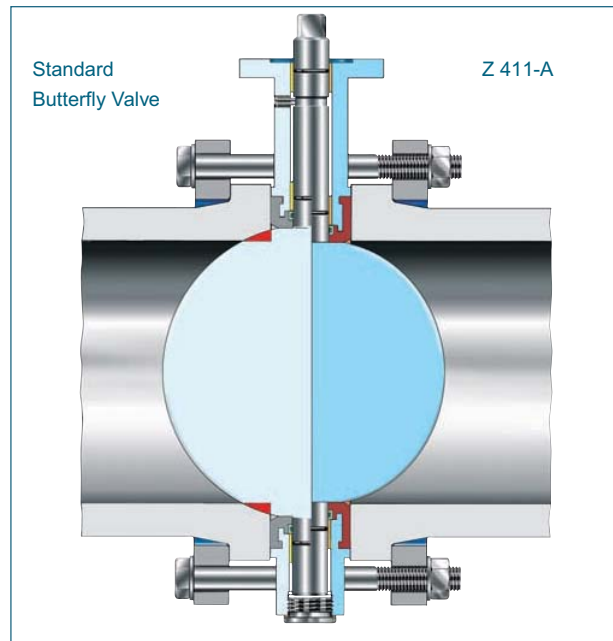

WAFER TYPE BUTTERFLY VALVE Z 411-A SDR 11

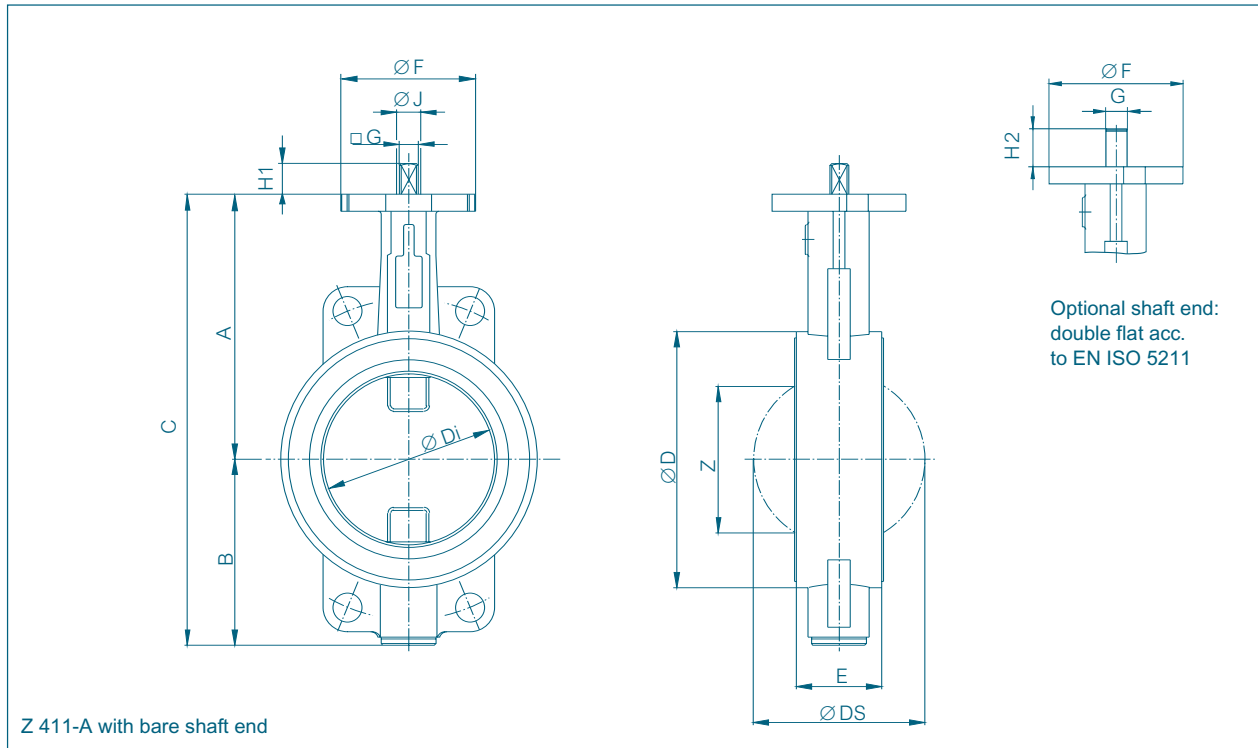

DN [mm]	Ø = da [mm]	Dimensions [mm]													Weight [kg]			
		A	B	C	D	Di	DS	E	F	Flange	G	H1	H2	J	Z	GGG40	AI	Splitted Shaft
40	50	113	66	179	80	37	38	33	54	F04	11	12	19	14	22	1,8	–	–
50	63	126	84	210	95	48,5	49,6	43	54	F04	11	12	19	14	25	2,2	–	1,5
65	75	134	93	227	115	63,5	64,6	46	54	F04	11	12	19	14	45	2,9	–	1,8
80	90	157	104	261	138	78,5	79,6	46	65	F05	14	16	25	18	65	4,0	–	2,1
100	110	167	115	282	158	98,5	99,2	52	65	F05	14	16	25	18	85	5,2	–	2,5
100	125	167	115	282	158	98,5	99,2	52	65	F05	14	16	25	18	85	7,5	–	2,5
125	140	180	127	307	166	111,2	112,2	56	65	F05	14	16	25	18	98	8,5	–	3,1
150	160	203	150	353	186	123,2	124,2	56	90	F07	17	19	30	22	111	10,0	–	4,9
150	180	203	150	353	212	148	149,2	56	90	F07	17	19	30	22	139	10,8	–	6,0
200	200	228	176	404	226	161,5	162,5	60	90	F07	17	19	30	22	151	11,2	–	6,6
200	225	228	176	404	250	182	183	60	90	F07	17	19	30	22	173	12,5	–	7,2
250	250	266	212	478	268	198,2	199,2	68	90	F07	17	19	30	22	188	19,0	–	7,6
250	280	266	212	478	315	224,3	225,3	68	125	F10	22	24	39	30	215	20,5	–	12,0
300	315	293	237	528	358	255	256	78	125	F10	22	24	39	30	244	28,0	–	18,0
350	355	332	269	601	365	285,7	286,7	92	125	F10	22	24	39	30	272	36,0	–	18,6
400	400	363	314	677	428	327	328	102	150	F12	*	*	–	40	312	–	68,0	–
500	450	437	405	842	454	365,8	366,8	127	150	F12	*	*	–	40	345	–	97,0	–
500	500	437	405	842	508	409	410	127	150	F12	*	*	–	40	390	–	105,0	–
600	560	475	418	893	530	426	427	114	210	F16	*	*	–	50	412	–	120,0	–
600	630	475	418	893	574	488	490	127	211	F17	*	*	–	50	473	–	135,0	–

* according to the mounted actuator

Subject to change without notice.

WAFER TYPE BUTTERFLY VALVE Z 411-A SDR 17 / 17,6

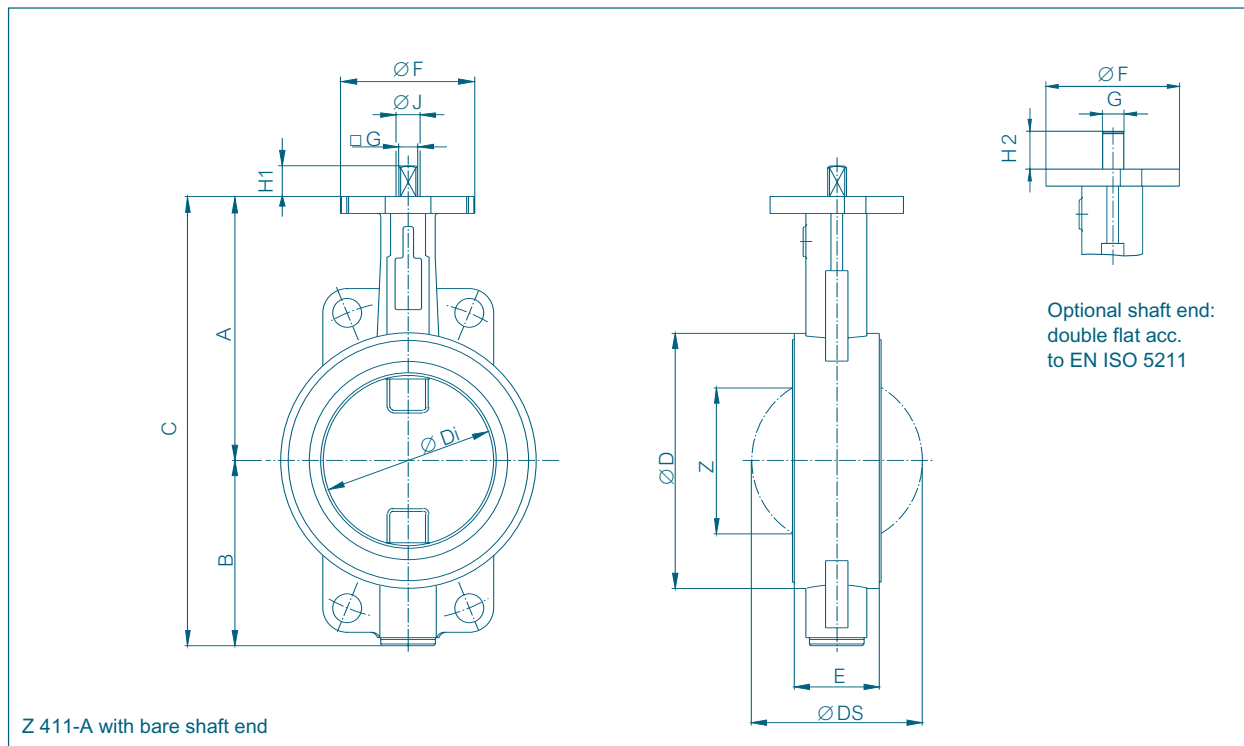

DN [mm]	Ø = da [mm]	Dimension [mm]													Weight [kg]				
		A	B	C	D	Di	DS	E	F	Flange	G	H1	H2	J	Z	GGG40	AI	Splitted Shaft	TS- Shaft
40	50	113	66	179	80	37	38	33	54	F04	11	12	19	14	22	1,8	-	-	
50	63	126	84	210	95	48,5	49,6	43	54	F04	11	12	19	14	25	2,2	-	1,5	
65	75	134	93	227	115	63,5	64,6	46	54	F04	11	12	19	14	45	2,9	-	1,8	
80	90	157	104	261	138	78,5	79,6	46	65	F05	14	16	25	18	65	4,0	-	2,1	
100	110	167	115	282	158	98,5	99,2	52	65	F05	14	16	25	18	85	5,2	-	2,5	
100	125	167	115	282	158	98,5	99,2	52	65	F05	14	16	25	18	85	7,5	-	2,5	
125	140	180	127	307	188	123,5	124,2	56	65	F05	14	16	25	18	111	9,5	-	3,5	
150	160	203	150	353	186	123,2	124,2	56	90	F07	17	19	30	22	111	10,0	-	4,9	
150	180	203	150	353	212	148	149,2	56	90	F07	17	19	30	22	139	10,8	-	6,0	
200	200	228	176	404	226	161,5	162,5	60	90	F07	17	19	30	22	151	11,2	-	6,6	
200	225	228	176	404	268	198,2	199,2	60	90	F07	17	19	30	22	190	14,0	-	7,5	
250	250	266	212	478	268	198,2	199,2	68	90	F07	17	19	30	22	188	19,0	-	7,6	
250	280	266	212	478	320	248	249,2	68	125	F10	22	24	39	30	240	23,0	-	13,0	
300	315	291	237	528	358	255	256	78	125	F10	22	24	39	30	244	28,0	-	18,0	
350	355	332	269	601	392	311,4	312,4	92	125	F10	22	24	39	30	299	38,0	-	20,0	
400	400	363	314	677	437	349,6	350,6	102	150	F12	*	*	-	40	336	-	75,0	-	
500	450	437	405	842	454	365,8	366,8	127	150	F12	*	*	-	40	345	-	97,0	-	
500	500	437	405	842	546	439,6	440,6	127	150	F12	*	*	-	40	422	-	112,0	-	
600	560	-	-	-	-	-	-	-	-	-	-	-	-	-	-	-	-	-	-
600	630	-	-	-	-	-	-	-	-	-	-	-	-	-	-	-	-	-	-

* according to the mounted actuator

Subject to change without notice.

WAFER TYPE BUTTERFLY VALVE Z 411-A SDR 33

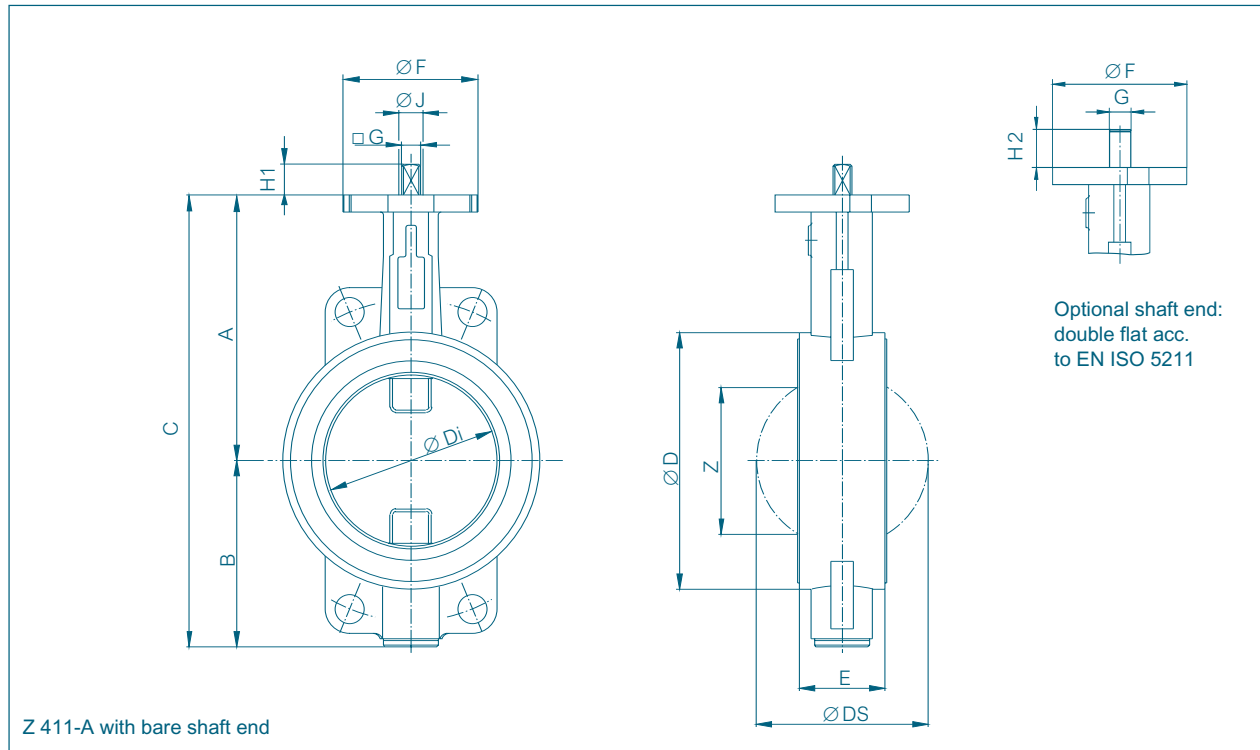

DN [mm]	Ø = da [mm]	Dimensions [mm]														Weight [kg]		
		A	B	C	D	Di	DS	E	F	Flange	G	H1	H2	J	Z	GGG40	AI	Splitted Shaft
40	50	113	66	179	80	37	38	33	54	F04	11	12	19	14	22	1,8	-	-
50	63	126	84	210	95	48,5	49,6	43	54	F04	11	12	19	14	25	2,2	-	1,5
65	75	134	93	227	115	63,5	64,6	46	54	F04	11	12	19	14	45	2,9	-	1,8
80	90	157	104	261	138	78,5	79,6	46	65	F05	14	16	25	18	65	4,0	-	2,1
100	110	167	115	282	158	98,5	99,2	52	65	F05	14	16	25	18	85	5,2	-	2,5
100	125	167	115	282	158	98,5	99,2	52	65	F05	14	16	25	18	85	7,5	-	2,5
125	140	180	127	307	188	123,5	124,2	56	65	F05	14	16	25	18	111	9,5	-	3,5
150	160	203	150	353	212	148	149,2	56	90	F07	17	19	30	22	139	11,0	-	5,4
150	180	203	150	353	212	148	149,2	56	90	F07	17	19	30	22	139	10,8	-	6,0
200	200	228	176	404	250	182	183	60	90	F07	17	19	30	22	173	14,0	-	7,2
200	225	228	176	404	268	198,2	199,2	60	90	F07	17	19	30	22	190	16,0	-	7,5
250	250	266	212	478	308	224,3	225,3	68	90	F07	17	19	30	22	215	22,0	-	8,0
250	280	266	212	478	320	248	249,2	68	125	F10	22	24	39	30	240	23,0	-	13,0
300	315	291	237	528	358	279,6	280,6	78	125	F10	22	24	39	30	270	30,0	-	19,5
350	355	332	269	601	392	311,4	312,4	92	125	F10	22	24	39	30	299	38,0	-	20,0
400	400	363	314	677	437	349,6	350,6	102	150	F12	*	*	-	40	336	-	75,0	-
500	450	437	405	842	508	409	410	127	150	F12	*	*	-	40	390	-	105,0	-
500	500	437	405	842	546	439,6	440,6	127	150	F12	*	*	-	40	422	-	112,0	-
600	560	-	-	-	-	-	-	-	-	-	-	-	-	-	-	-	-	-
600	630	-	-	-	-	-	-	-	-	-	-	-	-	-	-	-	-	-

* according to the mounted actuator

Subject to change without notice.

WAFER TYPE BUTTERFLY VALVE Z 411-A

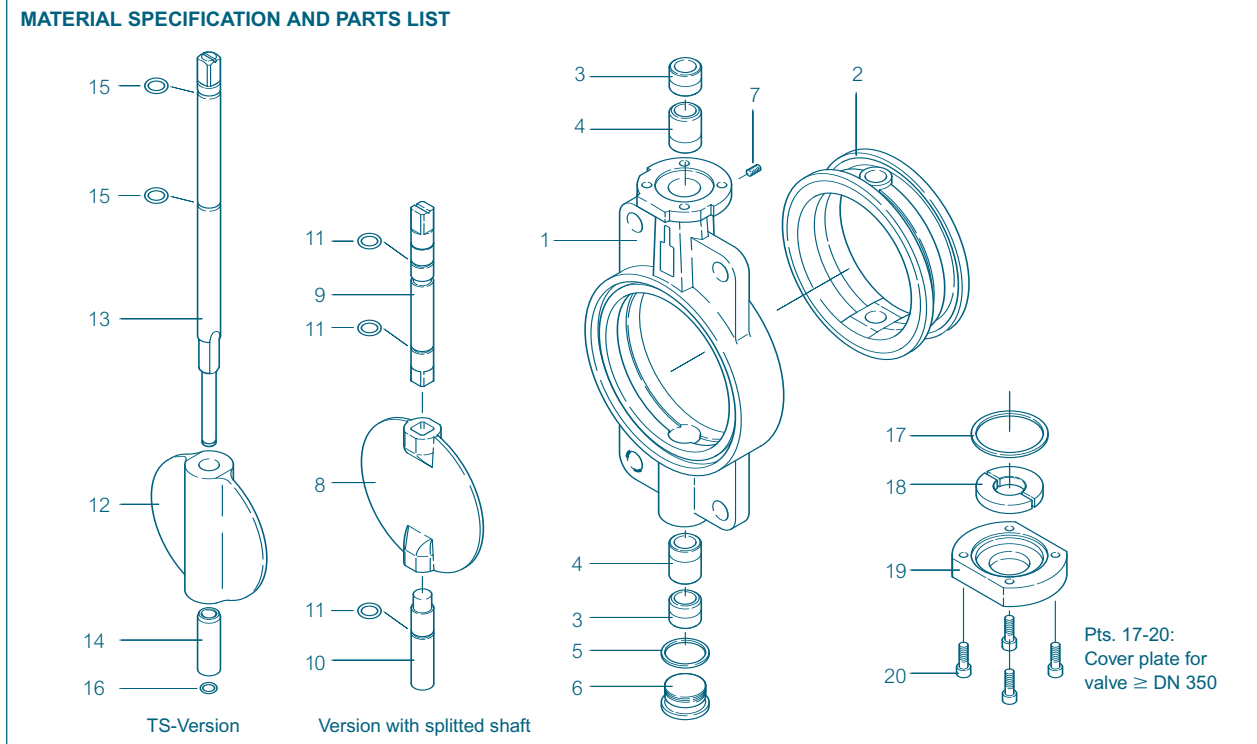

Pt.	Description	Material	Material-No.	ASTM	Pt.	Description	Material	Material-No.	ASTM
1	Body				12	TS-disc da250-da630			
	da63-da355					Nodular Cast Iron	GGG-40	0.7040	60-40-18
	Aluminiumalloy	G-AISI9Cu3	3.2163	B 380.1		Stainless Steel	X6CrNiMo10-20	1.4408	CF8M
	da63-da630					Aluminium Bronze	CuAl10Ni	2.0975	C 95800
	Nodular Cast Iron	GGG-40	0.7045	60-40-18		Coating	Halar, Rilsan		
2	Seat					Surface Quality			electropolished, mirror finished
	NBR	Acrylonitrile butadiene rubber			13	TS-shaft da250-da630			
	EPDM	Ethylene propylene caoutchouc				Stainless Steel	X14CrMoS17	1.4104	430F
	FPM	Fluorocarbon caoutchouc					X39CrMo17-1	1.4122	
3/4	Bearing bush						X5CrNiMo17-12-2	1.4401	316
	Brass	MS 58	2.0401	B 45	14	Sleeve			
	Polyamide					Stainless Steel	X5CrNi18-10	1.4301	304
5	Seal DIN 7603				15	O-ring			
	Stainless Steel	X5CrNiMo17-12-2	1.4401	316		NBR	Acrylonitrile butadiene rubber		
	PTFE					FPM	Fluorocarbon caoutchouc		
	Copper	Cu		Copper	16	Retainin ring			
6	Plug screw DIN 908					Stainless Steel	X39CrMo17-1	1.4122	
	Stainless Steel	G-X6CrNiMo 18-10	1.4408	CF8M	17	O-ring da400-da630			
	Steel	45 H galvanized				NBR	Acrylonitrile butadiene rubber		
	Stainless Steel	A4-70		B8M	18	Shaft retainer da400-da630			
8	Disc					Brass	MS 58	2.0401	B45
	Stainless Steel	X5CrNi18-10	1.4301	304	19	Cover plate da400-da630			
		X5CrNiMo18-10	1.4401	316		Grey Cast Iron	GG-25	0.6025	40 B
		G-X6CrNiMo18-10	1.4408	CF8M	20	Screw da400-da630			
	Coating	Halar, Rilsan				Steel	45 H galvanized		
	Surface Quality	electropolished, mirror finished				Stainless Steel	A2-70		B8
							A4-70		B8M
9/10	Shafts								
	Stainless Steel	X14CrMoS17	1.4104	430F					
		X5CrNiMo17-12-2	1.4401	316					
11	O-ring								
	NBR	Acrylonitrile butadiene rubber							
	FPM	Fluorocarbon caoutchouc							Other materials upon request.

Subject to change without notice

WAFER TYPE BUTTERFLY VALVE Z 411-A

TORQUE

- The torque values specified (Md) are based on liquid and lubricant media.
- Powdery (non-lubricant) media
Md x 1,3
- Dry gases/high viscous media
Md x 1,2
- The values specified are based on the initial breakaway torque.
- Dynamic torque specification available upon request.

Regarding the dimensioning of actuators please contact our engineers.

da [mm]	Size [in]	Operating pressure		
		SDR 11 10 bar	SDR 17 / 17,6 10 bar	SDR 33 6 bar
50	1½	6	6	6
63	2	7	7	7
75	2½	15	15	9
90	3	18	18	10
110	4	28	28	18
125	4	28	28	18
140	5	45	45	22
160	6	110	110	45
180	6	110	110	45
200	8	140	140	76
225	8	140	140	76
250	10	200	200	180
280	10	200	200	180
315	12	220	220	200
355	14	360	360	310
400	16	620	620	540
450	20	730	730	650
500	20	960	960	890
560	24	1580	-	-
630	24	2000	-	-

All values in Nm

K_V-VALUES

- The K_V-value (m³/per hour) is the flow of water at a temperature of 5 °C to 30 °C (41 °F to 86 °F) at Δp of 1 bar.
 - The K_V-values specified are based on tests carried out by the Delfter Hydraulics Laboratories, the Netherlands.
 - Permissible velocity of flow
V_{max} 4,5 m/s for liquids and
V_{max} 70 m/s for gases.
 - The throttle function is linear at an angle 30° to 70°.
 - Avoid cavitation!
- For further values, please contact our engineers.

da [mm]	DN [mm]	Size [in]	Opening angle α°									
			20°	2,2	8	15	21	33	43	50		
50	40	1½	11									
			17	2,2	8	15	21	33	43	50		
			33	2,2	8	15	21	33	43	50		
63	50	2	11	1,2	8	13	22	38	50	65	85	
			17	1,2	8	13	22	38	50	65	85	
			33	1,2	8	13	22	38	50	65	85	
75	65	2½	11	2	9	22	42	77	115	170	215	
			17	2	9	22	42	77	115	170	215	
			33	2	9	22	42	77	115	170	215	
90	80	3	11	8	24	50	95	150	240	330	420	
			17	8	24	50	95	150	240	330	420	
			33	8	24	50	95	150	240	330	420	
110	100	4	11	13	28	65	130	180	340	550	800	
			17	13	28	65	130	180	340	550	800	
			33	13	28	65	130	180	340	550	800	
125	100	4	11	13	28	65	130	180	340	550	800	
			17	13	28	65	130	180	340	550	800	
			33	13	28	65	130	180	340	550	800	
140	125	5	11	19	46	98	182	272	445	720	950	
			17	26	65	130	230	350	530	870	1010	
			33	26	65	130	230	350	530	870	1010	
160	150	6	11	26	65	130	230	350	530	870	1010	
			17	26	65	130	230	350	530	870	1010	
			33	35	90	200	360	640	900	1350	2100	
180	150	6	11	35	90	200	360	640	900	1350	2100	
			17	35	90	200	360	640	900	1350	2100	
			33	35	90	200	360	640	900	1350	2100	
200	200	8	11	37	120	240	429	740	1100	1870	2650	
			17	37	120	240	429	740	1100	1870	2650	
			33	41	160	310	520	900	1420	2480	3390	
225	200	8	11	41	160	310	520	900	1420	2480	3390	
			17	43	180	350	580	1000	1600	3000	4000	
			33	43	180	350	580	1000	1600	3000	4000	
250	250	10	11	43	180	350	580	1000	1600	3000	4000	
			17	43	180	350	580	1000	1600	3000	4000	
			33	85	270	510	840	1410	2400	4150	5200	
280	250	10	11	85	270	510	840	1410	2400	4150	5200	
			17	125	360	660	1100	1800	3100	5300	6400	
			33	125	360	660	1100	1800	3100	5300	6400	
315	300	12	11	133	390	710	1160	1900	3400	5500	6600	
			17	133	390	710	1160	1900	3400	5500	6600	
			33	170	480	870	1410	2300	4250	6650	7690	
355	350	14	11	185	500	920	1480	2420	4500	7000	8000	
			17	240	610	1110	1820	3000	5750	8400	9320	
			33	240	610	1110	1820	3000	5750	8400	9320	
400	400	16	11	285	680	1230	2050	3400	6680	9300	10200	
			17	350	780	1400	2400	4000	8000	10800	11500	
			33	350	780	1400	2400	4000	8000	10800	11500	
450	500	20	11	395	870	1530	2630	4500	8900	11100	12500	
			17	395	870	1530	2630	4500	8900	11100	12500	
			33	480	1030	1800	3120	5500	10700	12700	16000	
500	500	20	11	480	1030	1800	3120	5500	10700	12700	16000	
			17	500	1070	2000	3300	5900	11300	14000	18800	
			33	500	1070	2000	3300	5900	11300	14000	18800	
560	600	24	11	540	1120	2100	3500	6300	11600	15000	21000	
			17									
			33									
630	600	24	11	610	1300	2400	4100	7200	12500	17600	24000	
			17									
			33									

Subject to change without notice.



V&A

www.valve.co.za

Johannesburg Tel : 011-397 2833
 Fax : 011-397 4700
 E-mail : sales.jhb@valve.co.za
 Durban Tel : 031-579 2593
 Fax : 031-579 2562
 E-mail : sales@valve.co.za