

### Primary characteristics

NAF pneumatic actuators are designed for 90° rotation, and the actuator delivers its maximum torque in the closed position (0°) of the valve, which is normally the position in which maximum torque is needed for ball, ball sector and butterfly valves.

- intended for both on/off and control
- internal air passages - no external pipes
- limit position adjustments in both directions of travel
- maintenance-free
- double-acting or single-acting, with spring return
- includes provision for direct-mounting of valve positioner, solenoid valve and limit position switches
- piston rod mounted in PTFE bearings for smooth operation
- flexible system of sleeves for different stem diameters



### Design

The linear travel of the pistons is converted by a linkage into rotary travel at the actuator lever. The piston rod and the links has PTFE-coated bearings. This relieves the pistons of transverse loads, which ensures smooth operation. If only one cylinder is used, the piston rod at the other end is protected by a protective cylinder. The limit positions of the actuator can be adjusted by means of a stop screw in the end cover of each cylinder.

To obtain the "spring to close" and "spring to open" function, the cylinder containing the spring assembly is mounted on different sides of the actuator housing. The spring assembly is preloaded in the cylinder and, due to its special design, the cylinder can be removed without the need for removing the preloaded spring assembly. On actuators sizes 1 - 3, the torque is transmitted from the actuator to the valve stem by means of a sleeve. The sleeve system offers wide flexibility, since a given actuator size can easily be adapted for different stem diameters. On actuator sizes 0, 4 and 5, the actuator is equipped with a lever for the appropriate stem diameter and the torque is transmitted directly.

NAF-Turnex actuators are provided with internal compressed-air passages. Compressed air is connected to two threaded ports in the centre of the actuator. Visual indication showing the angular position of the actuator/valve is provided at the top of the actuator.

Sizes 0 - 4 of NAF-Turnex actuators are provided with connections for direct-mounting of solenoid valves conforming to the NAMUR standard. An intermediate plate is used for mounting solenoid valves conforming to other standards. The actuator is also equipped for direct-mounting of valve positioners and limit switches. Special emergency operating equipment can be fitted to the actuator for operating the valve in the event of loss of compressed air supply.

#### Technical data

Temperature range:	-30°C* to +80°C
Operating pressure:	Up to 8 bar gauge pressure (delivers nominal torque at 5 bar gauge)
Operating medium:	Air
Total motion	Approx.: 96°

\*-40°C on request

**Material**  
**791290/791390 Size 0 -5**

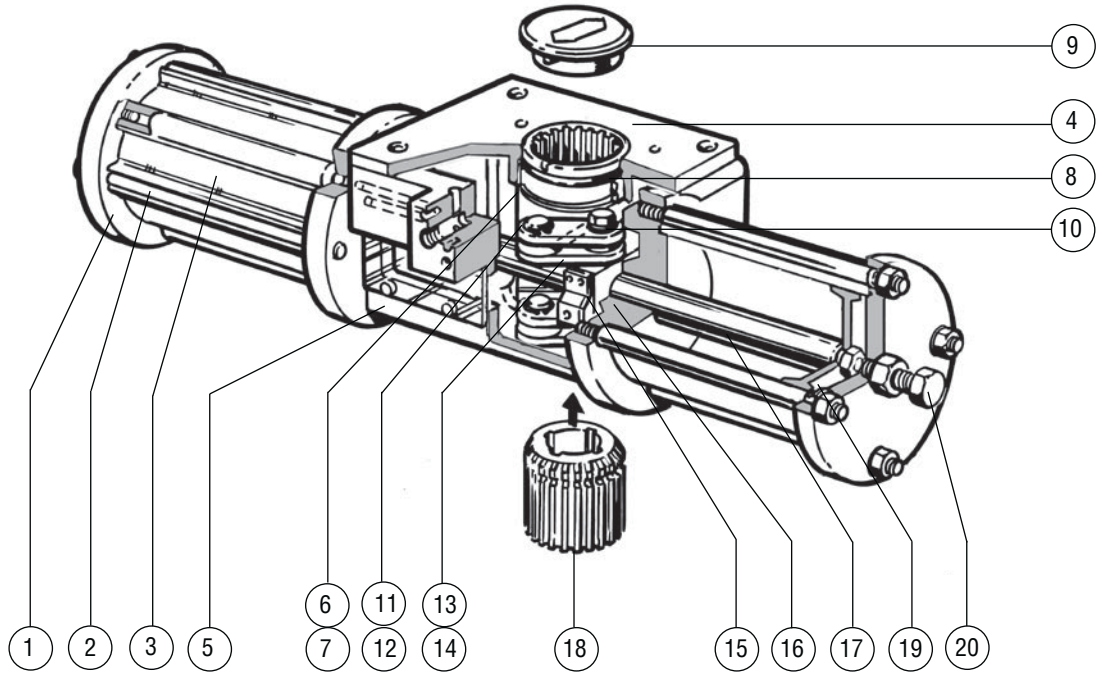

**791.92/94 Size 0 -3 with spring return**

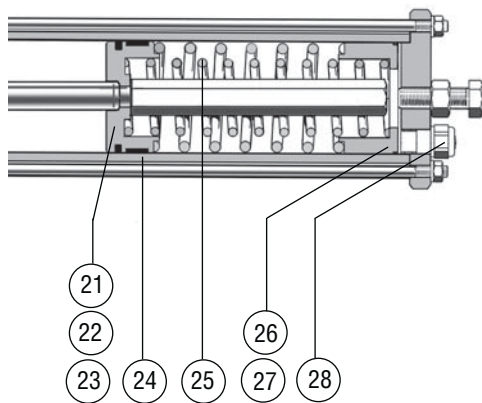

**791390 Size 4-5**

Spring return design has a lengthened cylinder (3).

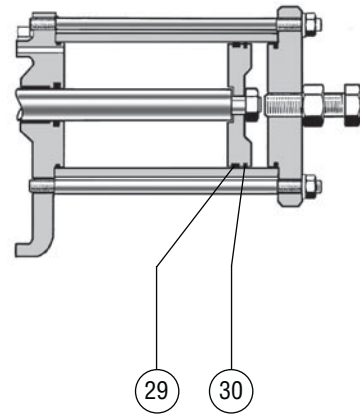

**(Table 1)**

Pos.	Qty.	Size	Description	Material
1	2	0—5	Cylinder cover	Al
2	8	0—5	Tie rod	Stainless steel
3	2 <sup>1)</sup>	0—5	Cylinder	Al
4	1	0—5	Cover	Al
5	1	0—5	Housing	Al
6	1	0	Lever	Stainless steel
6	1	1—5	Lever	SG Iron
7	1	0—3	Circlip for sleeve	Stainless steel
8	2	0	Bearing for lever	Polyamide
8	2	1—5	Bearing for lever	Acetal plastic
9	1	0—5	Visual indicator	Al
10	1	0—3	Pin	Steel
11	2	0—5	Pivot pin	Steel
12	2	0—5	Pivot pin bearing	Glacier DU
13	2	0—5	Link	Steel
14	2	0—5	Bearing for link	Steel
15	1	0—5	Coupling	Steel

1) 1 pce for single-acting actuator with spring return.

**(Table 2)**

No.	Qty.	Size	Description	Material
16	2	0—5	Bearing for piston rod	Glacier DU
17	1	0—5	Piston rod	Stainless steel
18	1	1—3	Sleeve	Stainless steel
19	2 <sup>1)</sup>	0—3	Piston	Steele/nitrile
19	2 <sup>1)</sup>	4—5	Piston	Al
20	2	0—5	Stop screw	Stainless steel
21*	1	0—5	Spring piston	Al
22*	1	0—5	Bearing for spring piston	Acetal plastic
23*	1	0—3	Seal	PTFE/nitrile
23*	1	4—5	Seal	NBR
24*	1	0—5	Spring cylinder	Al
25*	2-3	0—5	Spring	Steele
26*	1	0—3	Inner cover	Al or steele
27*	2	0—3	Circlip	Stainless steel
28*	1	0—5	Filter	Brass/galvanized
29	1	4—5	Piston bearing	Acetal plastic
30	1	4—5	Piston seal	NBR

\* Only for single-acting actuator with spring return.

**(Table 3)**

NAF No	Cylinder diameter mm	Cylinder volume dm <sup>3</sup>	Max. stem diameter mm	Max. torque at 5 bar Nm
<b>Double-acting</b>				
791390-02XX <sup>1)</sup>	50	0,3	25	100
791290 -11	63	0,3	25	100
-12	63	0,6	25	200
-21	100	1,15	40	400
-22	100	2,3	40	800
-31	160	3,45	50	1300
-32	160	6,9	50	2600
791390 -41	200	6,25	80	2500
-42	200	12,5	80	5000
-51	320	24	100	10000
-52	320	48	100	20000
<b>Spring to close</b>				
791392-02XX <sup>1)</sup>	50	0,3	25	60
791292 -12	63	0,6	25	125
-22	100	2,3	40	500
-32	160	6,9	50	1650
791392 -42	200	12,5	80	3200
-52	320	48	100	13260
<b>Spring to open</b>				
791394-02XX <sup>1)</sup>	50	0,3	25	65
791294 -12	63	0,6	25	135
-22	100	2,3	40	540
-32	160	6,9	50	1770
791394 -42	200	12,5	80	3500
-52	320	48	100	14220

1) XX = inside diameter of sleeve. See the table on page 8. Example: 791290-1125 = sleeve for 25 mm stem dia. For 100 mm stem dia., state XX=00. For an actuator without sleeve, omit XX, e.g. 791290-12. The torque delivered by double-acting actuators at supply pressures other than 5 bar changes proportionately with the supply pressure. At 6 bar, the torque will be 6:5 = 1.2 x nominal torque of the relevant actuator. For particulars of single-acting actuators with spring return, consult your NAF representative if the supply pressure is other than 5 bar.

## Torques

Torques of the double-acting NAF 791290/791390 actuator as a function of angle.

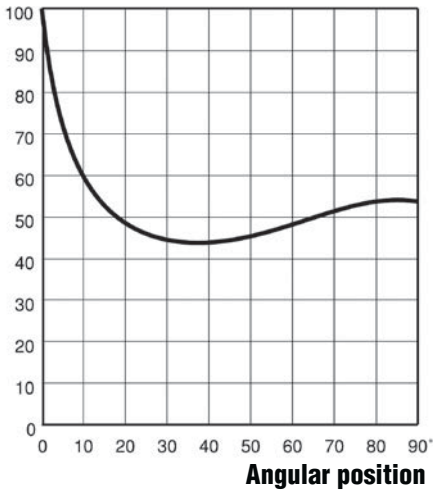

Torque of the single-acting, spring-closing NAF 791292/791392 actuator at 5 bar gauge as a function of angle.

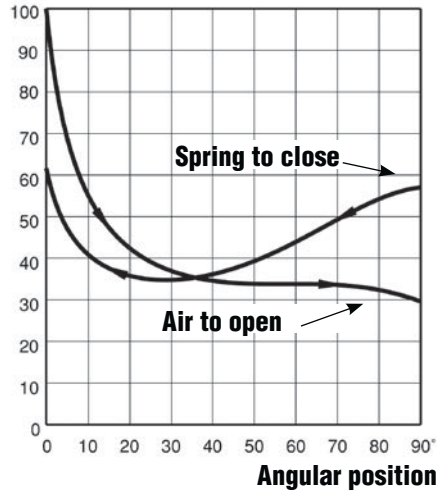

Torque of the single-acting, spring-opening NAF 791294/791394 actuator at 5 bar gauge as a function of angle.

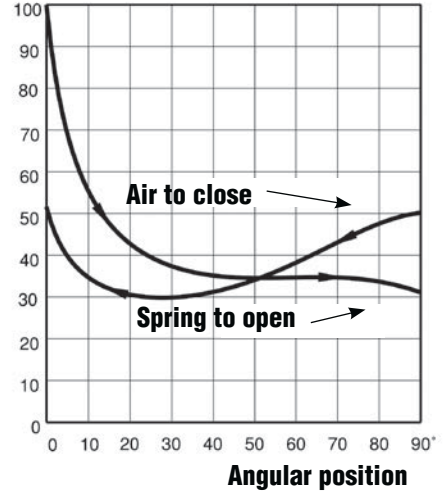

## Dimensions and mass

### Double-acting actuators

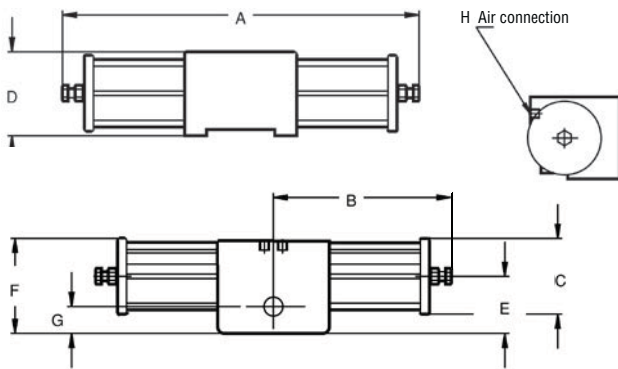

### Single-acting actuators

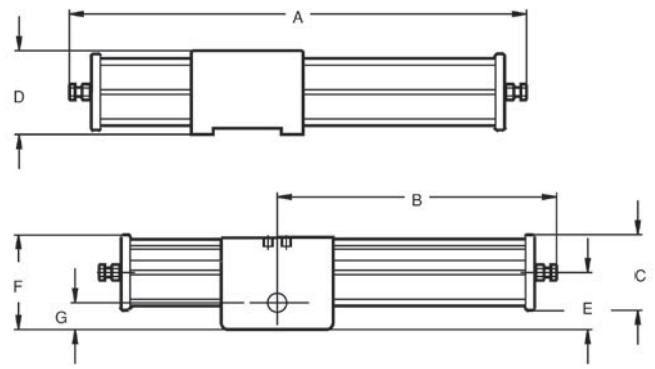

(Table 4)

NAF No.	Actuator size	A	B	C	D	E	F	G	H	Mass kg
791390	02	370	185	80	102	63	108	32	G1/4"	4
791290	11-12	490	245	100	112	78	130	38	G1/4"	6
	21-22	700	350	145	148	117	190	54	G1/4"	17
	31-32	820	410	200	200	130	230	55	G1/4"	29
791390	41-42	1110	555	260	260	176	310	76	G1/4"	66
	51-52	1600	800	395	330	252	450	102	G3/8"	220
791392/94	02	455	270	80	102	63	108	32	G1/4"	5
791292/94	12	635	390	100	112	78	130	38	G1/4"	9
	22	890	540	145	148	117	190	54	G1/4"	25
	32	1050	640	200	200	130	230	55	G1/4"	43
791392/94	42	1520	965	260	260	176	310	76	G1/4"	100
	52	2210	1370	395	330	252	450	102	G3/8"	485

### **Accessories**

NAF's pneumatic actuators, see data sheet Fk74.59 can be equipped with a large number of accessories.

The following are included in NAF's standard programme and are suitable for direct mounting to NAF pneumatic actuators.

### **Valve positioner**

Pneumatic and electro-pneumatic valve positioner, see data sheet Fk41.82.

Intelligent valve positioner, see data sheet Fk41.85.

Intelligent On/Off controller, see data sheet Fk41.86.

### **Solenoid valves**

See data sheet Fk79.17.

### **Electrical position indication**

See data sheet Fk79.10.

### **Terminal box**

The actuator can be equipped with a junction box (part No. 349 20 930) of cast aluminium containing terminal blocks for connecting the solenoid valve and position sensors.

For mounting on NAF-Turnex size 0 a mounting plate is needed, part no. 32275750.

For NAF-Turnex size 0 mounted in line with the pipe, a mounting plate is needed, part no. 32278490.

For other sizes of NAF-Turnex the terminal box is mounted directly on the actuator.

### **Explosive atmosphere according to Directive 94/9/EC ATEX**

NAF-Turnex is certified according to ATEX 94/9/EC in  II 2 G/D c.  
*Product code: 791.9.-...XA*

## Other versions

### - Permanently mounted emergency lever

Available for actuator size 0-3. With handwheel and long screw, intended for permanent mounting on NAF-Turnex. This screw is also endstop and must be restored to its original position and locked with the handwheel after the emergency operation.

**Note!** The manoeuvre shall only be done without air supply.

Part No.	Lever diam.	Intended for actuator
799959-0	100	791390/92/94-0
799959-1	160	791290/92/94-1
799959-2	200	791290/92/94-2
799959-3	315	791290/92/94-3

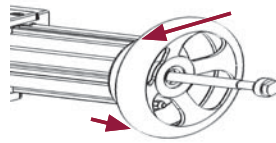

**Step 1**  
Unfasten the handwheel by turning it CCW to the end of the thread.

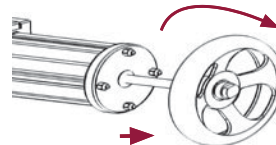

**Step 2**  
Move it to the other thread and turn it CW.

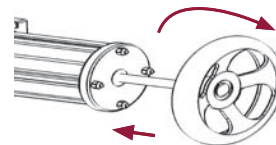

**Step 3**  
The actuator can be operated when the thread reaches the bottom.

### - Temperature below -30 °C

For temperature down to -40°C the actuator can be supplied with special seals/pistons.

*Product code: A*

### - Declutchable manual override

For manual operation, a declutchable actuator can be mounted between the valve and the pneumatic actuator. Contact NAF for further information

### - Screws/nuts in A4

All external screws and nuts including those for mounting of the actuator on the valve is replaced by A4 material

*Product code: S*

### - Parallel mounting of actuator in pipeline

NAF-Turnex can be supplied for parallel mounting in pipeline. Size 0 with special cover and size 1-5 with intermediate plate.

*Product code: L*

### Mounting the actuator on the valve (Table 5)

Size	Stem diameter (mm)	K	L	M
02-12	16, 20, 25	115	30	M10
21-22	16, 20, 25, 30, 35, 40	115	30	M10
		160	40	M12
		214	60	M16
31-32	25, 30, 35, 40, 45, 50	160	40	M12
		214	60	M16
41-42	30, 35, 40, 45, 50, 55, 60, 70, 80	160	40	M12
		214	60	M16
51-52	45, 50, 55, 60, 70, 80, 90, 100	214	60	M16
		277	115	M30

Actuator sizes 1, 2 and 3 have loose sleeves which can be mounted directly in the actuator lever, whereas on actuator sizes 0, 4 and 5, the lever item 6 must be suitable for the stem diameter.

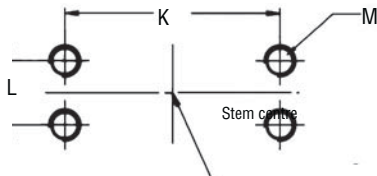

### Specification (Table 6)

NAF No.	Size	Function	
791290 791390	11-32 02, 41-52	Double-acting	Air to open / Air to close
791292 791392	12-32 02, 42-52	Single-acting with spring return	Spring to close (air to open)
791294 791394	12-32 02, 42-52	Single-acting with spring return	Spring to open (air to close)

### Ordering example

When placing an order, always specify

- NAF No., actuator size and stem diameter
- Description and any accessories

#### Example

NAF 791292 - 2225 NAF-Turnex, single-acting pneumatic actuator (spring to close, size 22, stem diameter 25 mm).

Accessories: NAF 370300-90P Electro-pneumatic valve positioner.