

**Primary characteristics**

NAF-Setball is a ball sector valve with metal-to-metal or metal-to-PTFE seating. The NAF-Setball combines the best control characteristics of the ball valve and the butterfly valve. It can be used both as a control valve and as a shut-off valve. It is available as standard in stainless steel. It is also available in other materials, such as, CG8M, Titanium, etc. Contact NAF for more information

The valve has:

- a one-piece, leak-proof stainless steel body, with face-to-face lengths in acc. with IEC standards
- a ball sector with top and bottom bearings for low operating torque, so that low-torque actuators can be used
- a V-shaped sector that provides accurate control over a wide range, even at low flow rates and if used for viscous media with high concentrations of solid particles
- a spherical area of the ball sector which, with PTFE-seat gives tight closing. The Stellite seat ring, ensures excellent tightness at all differential pressures. The maximum leakage in the direction of flow is less than  $5 \times 10^{-6}$  of the Kv value in this case.
- Metaloplast bearings.
- O-ring or graphite packing for the stem gland
- The standard Stellite seat can easily be converted to PTFE after turning the ball sector by 180 degrees, without the need to dismantle the valve.
- NAF standard for mounting the actuator, which simplifies installation and results in a compact valve/actuator unit

**CE-marked** according to Pressure Equipment Directive (PED 97/23/EG) module H, category III.  
 For module H1, category IV contact NAF

**Applications**

NAF-Setball can be used both as a control valve and as a shut-off valve, in a wide variety of applications and in different operating modes. The valve represents a concrete result of our product philosophy which is focused on functionality, high quality and low life cycle costs, and is based on concentrating our range to a limited number of valve types, but all of them suitable for a wide variety of applications.



The excellent control characteristics of NAF-Setball are particularly beneficial under severe control conditions, in difficult media and under demanding pressure conditions in the process industry, such as:

- if the media contains solid particles
- if a wide control range is required
- in control applications involving high pressure drops
- if cavitation occurs
- corrosive applications

**Technical specification**

Material:	Stainless steel
Size range:	DN 25-500
Pressure ratings:	PN 10, 16, 25, 40 ANSI Class 150 and 300
Max. differential pressures:	
valve closed	25 bar DN 25-400 20 bar DN 500
control service	25 bar DN 25-80 15 bar DN 100-150 10 bar DN 200-250 8 bar DN 300-400 6 bar DN 500
See also page 2	
Face-to-face lengths:	As per IEC 534-3-2
Installation methods:	Wafer type (DN 25-200) Flanged (DN 25-500)
Temperature range:	-30 - 250°C
Test pressure:	1.5 x PN with valve open IEC 534-4 Class IV-S1 with valve closed
Sealing class:	Testing medium is water. PTFE-seat ISO 5208-2 Rate A DIN 3230 BN Leckrate 1 Metal seat IEC 534-4 Class IV-S1.



### Working pressure, differential pressure and temperature

The maximum working pressure and temperature in the body depends on pressure class according to respectively flange standard. Max. differential pressure, valve closed, depends on temperature as shown in the diagram and is valid for all sizes. Max. differential pressure for control service and sizes DN 100-500 depends on size and temperature as shown in the diagram.

Valves with PTFE-seat is further limited as shown in the diagram.

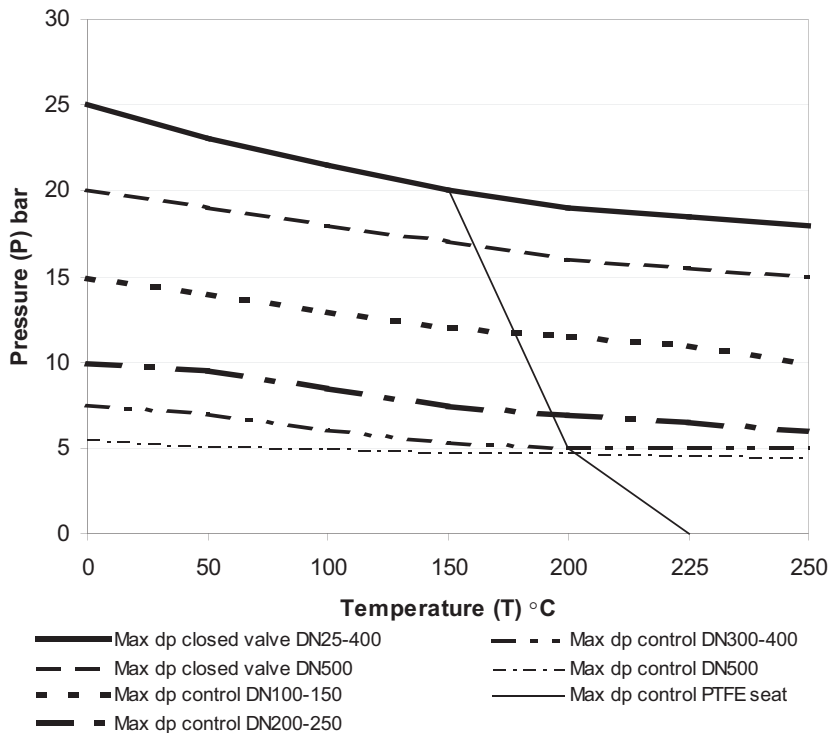

### Flow capacities and characteristics (Table 1)

DN/ Norm. Bore	Kv at an opening angle of								
	15°	20°	30°	40°	50°	60°	70°	80°	90° *
25/05	0,04	0,09	0,24	0,40	0,56	0,75	0,94	1,19	1,52
25/10	0,04	0,1	0,3	0,7	1,2	1,8	2,6	3,5	5,1
25/15	0,5	0,7	1,2	2,0	3,3	4,4	5,6	8,3	11,2
25/20	0,2	0,3	0,9	2,3	4,1	7,1	10	15	22
40	1,0	2,1	5,1	9,5	15	23	33	53	65
50	1,6	3,2	8,2	15	25	38	53	85	103
65	2,5	4	8	17	27	44	65	98	145
80	4	8	18	32	52	78	110	150	245
100	9	15	31	53	83	124	180	254	415
150	25	40	78	135	212	310	445	615	970
200	30	50	110	200	310	470	670	920	1250
250	33	80	200	337	575	830	1150	1560	2480
300	87	173	390	655	995	1410	1930	2580	3960
350	126	250	565	945	1430	2035	2780	3710	5705
400	171	340	765	1285	1950	2770	3785	5050	7765
500	205	435	990	1710	2600	3690	5045	6730	10350

$C_v = 1.16 \times K_v$

\* At demand for larger max Kv contact NAF.

## Materials

### Seat ring

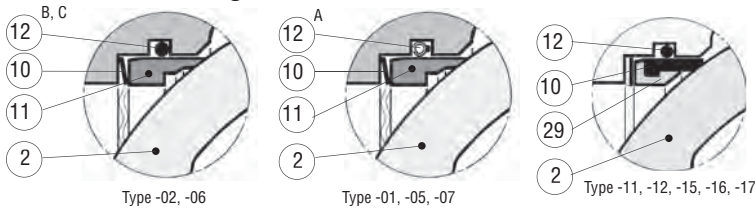

### Stem sealing

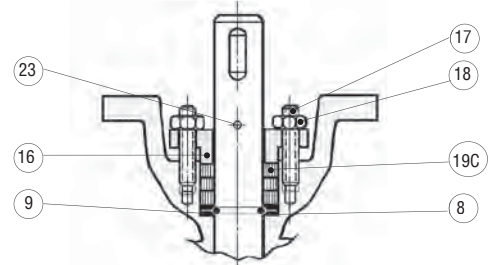

Stuffing box: Type -07, -17

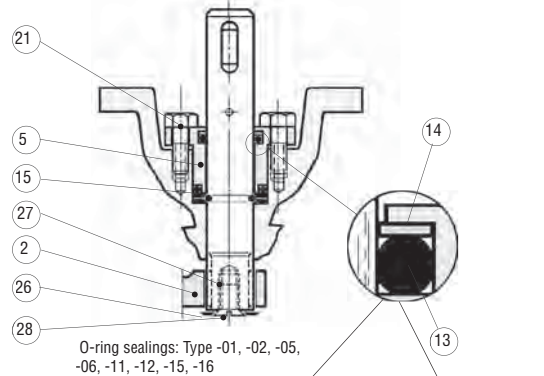

O-ring sealings: Type -01, -02, -05, -06, -11, -12, -15, -16

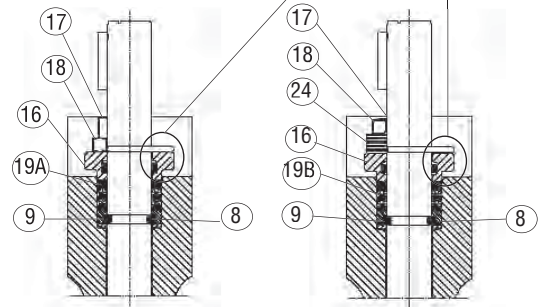

Zebra-CL™: Type 0A, 1A

Safeguard: Type 0B, 1B

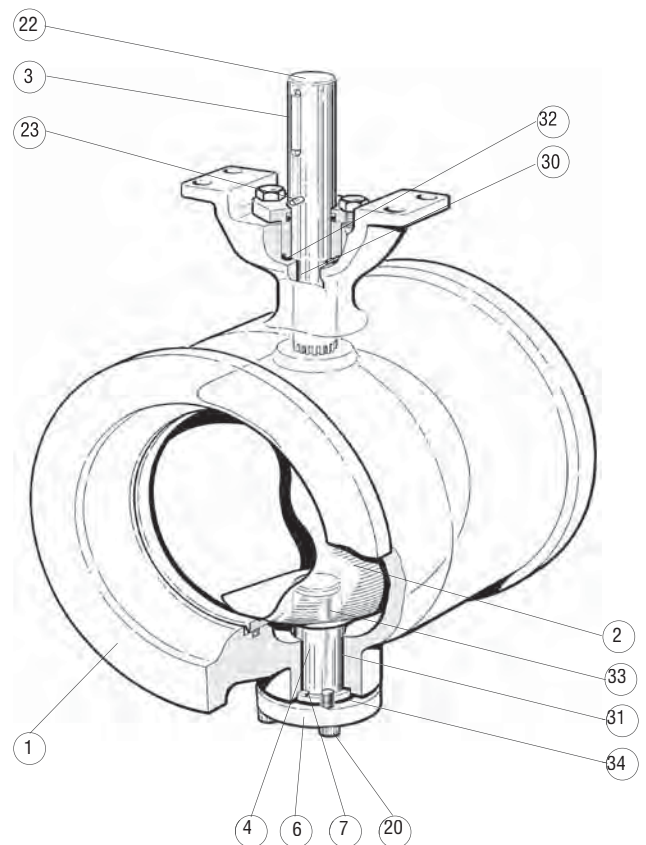

(Table 2)

Item	Qty	Part	Material	Sealing type
1	1	Body	EN1.4408/CF8M	
2	1	Ball sector	EN1.4408/CF8M hard chrome plated	01, 02, 05, 06, 07
2	1	Ball sector	EN1.4408/CF8M	11, 12, 15, 16, 17
3	1	Stem, upper	EN1.4460	
4	1	Stem, lower	EN1.4460	
5	1	Gland cover	EN1.4408/CF8M	01, 02, 05, 06, 11, 12, 15, 16
6	1	Bottom cover	EN1.4408/CF8M	
7	1	Gasket	Graphite	
8	1	Locking segment	EN1.4436	
9	1	Bearing seat	EN1.4460	
10	1	Compr ring	EN1.4436	
11	1	Seat ring	Alloy 6	01, 02, 05, 06, 07, 0A, 0B
12A	1	Seat seal	PTFE	01, 05, 07, 11, 15, 17, 1A, 1B
12B	1	Seat seal	EPDM	02, 12
12C	1	Seat seal	FPM	06, 16
13A	1	O-ring	EPDM	01, 02, 11, 12
13B	1	O-ring	FPM	05, 06, 15, 16
14	1	Backing ring	PTFE	01, 02, 05, 06, 11, 12, 15, 16
15A	1	O-ring	EPDM	01, 02, 11, 12
15B	1	O-ring	FPM	05, 06, 15, 16
16	1	Gland cover	EN1.4408/CF8M	07, 17,
17	2	Bolt	A4	07, 17, 0A, 0B, 1A, 1B
18	2	Nut	A4	07, 17, 0A, 0B, 1A, 1B
19A	1	Boxpacking Zebra-CL™	V-ring PTFE	0A, 1A
19B	1	Boxpacking Safeguard	V-ring PTFE liveloaded	0B, 1B
19C	1	Boxpacking	Graphite	07, 17
20	4	Bolt	A4	
21	2	Bolt	A4	01, 02, 05, 06, 11, 12, 15, 16
22	1	Key	Steel	
23	1	Indicating pin	SS	
24	1	Cup spring	EN1.4310	0B, 1B
26	1	Washer	A4	
27	1	Thread insert	Stainless	
28	1	Bolt	A4	
29	1	Seat ring / Back-up ring	PTFE/SS	11, 12, 15, 16, 17
30	1	Stem bearing	Metaloplast	
31	1	Stem bearing	Metaloplast	
32	1	Washer	A4	
33	1	Cylindrical pin	EN1.4460	
34	1	Washer	Metaloplast	

**Operating torque, Nm (Table 3)**

DN	Differential pressure bar				
	3	10	15	20	25
25	7	12	17	21	25
40	8	15	21	27	32
50	10	19	26	31	38
65	19	35	45	60	70
80	22	45	60	80	95
100	30	60	85	110	135
150	75	155	210	270	325
200	140	305	420	535	650
250	250	540	750	950	1160
300	430	885	1210	1535	1870
350	629	1325	1921	2318	2815
400	892	1830	2635	3171	3841
500	1120	2160	2990	3790	-

**Operating torque**

The minimum design torque for selecting the actuator is stated in the table for a differential pressure of 3 bar. The specified torques are for clean media. For steam increases the torque in above table with 20%. For pulp and other media containing solids consult your NAF representative.

**Sizing of control valves**

We have a valve calculation program which is advanced but very easy to use. This program can be ordered through your NAF representative. The program is based on the calculating formula according to the standards IEC 543, ISA 575.01 and VDMA 24422.

## Dimension and mass

Wafer version

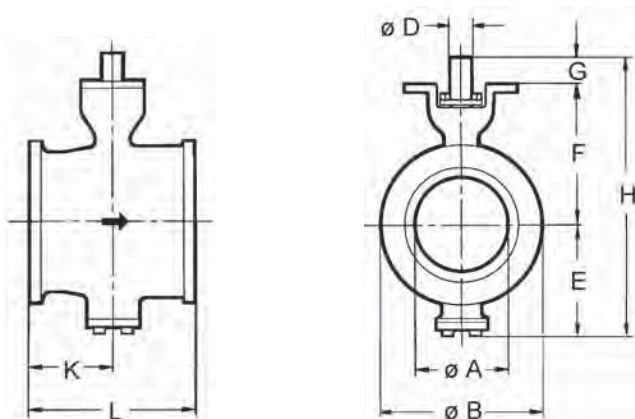

Flanged version

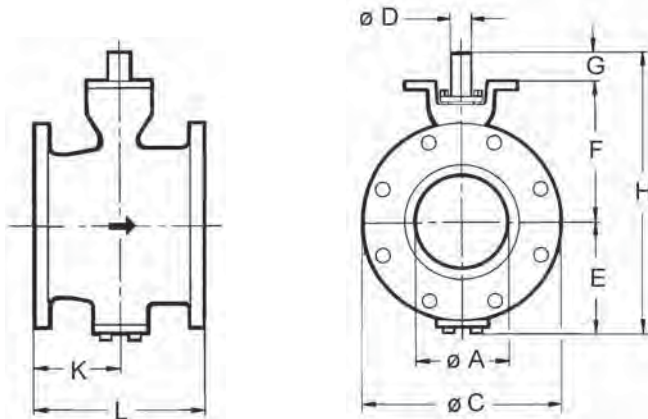

### NAF standard for actuator mounting

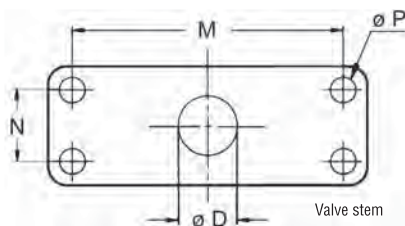

(Table 4)

DN	A	B	C <sup>1)</sup>	D	E	F	G	H	K	L	M	N	P	Mass, kg	
														Wafer	Flanged <sup>1)</sup>
25 <sup>3)</sup>	20	65	<sup>1)</sup>	20	60	120	43	225	51	102	115	30	11	4	7,2
40	32	86	<sup>1)</sup>	20	75	125	43	245	57	114	115	30	11	5,5	9,8
50	40	105	<sup>1)</sup>	20	90	131	43	265	62	124	115	30	11	6,5	13,0
65	50	122	<sup>1)</sup>	20	101	139	43	283	68	135	115	30	11	9	15,5
80	70	132	<sup>1)</sup>	20	110	145	43	300	83	165	115	30	11	11,5	18
100	85	162	<sup>1)</sup>	20	120	167	43	332	97	194	115	30	11	15,5	25
150	130	218	<sup>1)</sup>	25	155	195	50	400	115	229	115	30	11	26	41
200	170	273	<sup>1)</sup>	30	185	236	59	480	130	243	160	40	14	42	64
250	208	-	<sup>1)</sup>	35	230	295	65	590	155	297	160	40	14	-	100
300	258	-	<sup>1)</sup>	40	260	320	80	660	183	338	214	60	18	-	145
350	282	-	<sup>1)</sup>	50	290	360	93	742	200	400 <sup>4)</sup>	214	60	18	-	174
400	316	-	<sup>1)</sup>	50	308	383	93	784	224	400	214	60	18	-	211
500	400	-	<sup>1)</sup>	50	371	460	93	942	288	508	214	60	18	-	348

All dimensions in mm

1) See respectively flange diameter according to Fk 90.20

2) PN 10

3) For DN 25/20, 25/15, 25/10, 25/05

4) New face to face from variant 87xxEF

### Actuators

NAF-Setball is available with hand levers or with pneumatic or electric actuators and accessories.

Use the following tables for selecting the hand levers and standard pneumatic actuators.

If other pneumatic or electric actuators are required, consult your NAF representative.

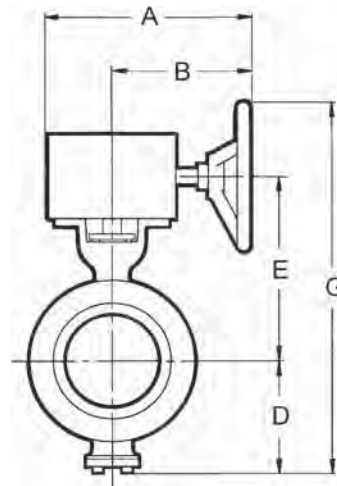
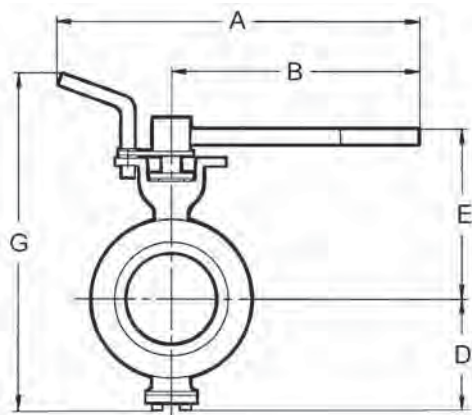

### NAF-Setball valves with hand levers (Table 5)

Size DN	Max dp bar	NAF No.	Dimensions, mm					Mass kg <sup>1)</sup>
			A	B	D	E	G	
Hand lever acc. to Fk 70.51								
25	25	791020-2	500	350	60	158	300	6
40	25	-2	500	350	75	163	320	7,5
50	25	-2	500	350	90	168	340	8,5
65	25	-2	500	350	101	176	348	11
80	25	-2	500	350	110	183	375	13
100	25	-2	500	350	120	205	497	18
150	10	-3	500	350	155	233	470	26
200	5	-4	615	450	185	273	550	45
Worm gear actuator acc. to Fk 70.76 <sup>2)</sup>								
25	25	791051-11020	249	174	60	154	314	8
40	25	791051-11020	249	174	75	159	334	9,5
50	25	791051-11020	249	174	90	165	355	10,5
65	25	791051-11020	249	174	101	173	374	13
80	25	791051-11020	249	174	110	179	389	15,5
100	25	791051-11020	249	174	120	201	421	19,5
150	25	791051-11025	249	174	155	229	484	30
200	25	791051-22030	328	243	185	279	614	51
250	16	791051-22035	328	243	230	338	718	109
250	25	791051-32035	416	291	230	345	775	117
300	25	791051-33040	416	291	260	370	830	162
350	16	791051-33050	416	291	290	425	915	191
350	25	791051-43050	507	337	290	415	955	206
400	25	791051-43050	507	337	308	438	996	243
500	20	791051-43050	507	337	371	515	1136	380

1) DN 25—200 Wafer version,  
DN 250—500 Flanged version, PN 10  
2) Available with locking device. Contact NAF.

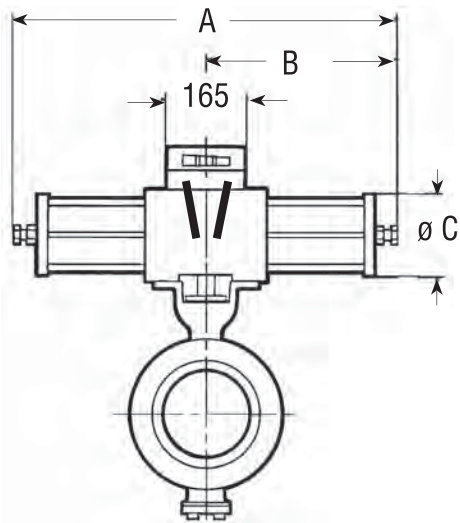

NAF 791290/791390

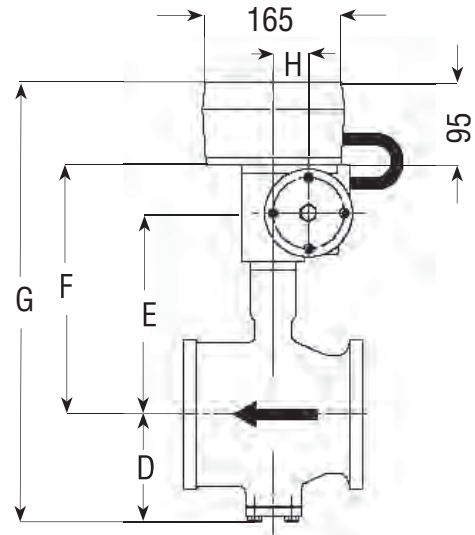

## NAF-Setball valves with pneumatic actuators (Table 6)

The below stated dP apply for clean media type water.  
For other media contact NAF, see also page 4.

Size DN	Max dP bar at supply of			NAF No.	Dimensions, mm								Mass kg <sup>2)</sup>
	4 bar	5 bar	6 bar		A	B	C	D	E	F	G 1)	H	
<b>Double-acting acc. to Fk 74.59</b>													
25	25	25	25	791290-0220	370	185	80	60	170	222	377	31	8
40	25	25	25	-0220	370	185	80	75	175	277	397	31	10
50	25	25	25	-0220	370	185	80	90	180	233	418	31	11
65	25	25	25	-0220	370	185	80	101	189	241	437	31	13
80	20	25	25	-0220	370	185	80	110	195	247	452	31	16
100	14	18	22	-0220	370	185	80	120	217	269	484	31	20
100	25	25	25	-1220	490	245	100	120	222	279	493	40	22
150	-	4	7	-0225	370	185	80	155	245	296	546	31	30
150	11	14	18	-1225	490	245	100	155	250	306	556	40	32
150	25	25	25	-2225	700	350	145	155	278	343	633	63	43
200	11	14	18	-2130	700	350	145	185	310	383	663	63	59
200	25	25	25	-2230	700	350	145	185	310	383	663	63	59
250	5	7	9	-2135	700	350	145	230	370	443	768	63	117
250	13	17	20	-2235	700	350	145	230	370	443	768	63	117
250	22	25	25	-3135	820	410	200	230	395	495	820	75	129
300	-	-	4	-2140	700	350	145	260	395	466	821	63	162
300	7	9	11	-2240	700	350	145	260	395	466	821	63	162
300	25	25	25	-3240	820	410	200	260	420	520	875	75	174
350	17	22	25	-3250	820	410	200	290	490	620	1005	100	219
350	25	25	25	791390-4250	1110	555	260	290	490	620	1005	100	219
400	11	15	20	791290-3250	820	410	200	308	483	613	1016	75	240
400	25	25	25	791390-4250	1110	555	260	308	513	643	1046	100	256
500	8	11	13	791290-3250	820	410	200	371	560	690	1156	75	377
500	20	20	20	791390-4250	1110	555	260	371	590	720	1186	100	393

1) Including NAF valve positioner

2) DN 25—200 Wafer version  
DN 250—500 Flanged version, PN 10.

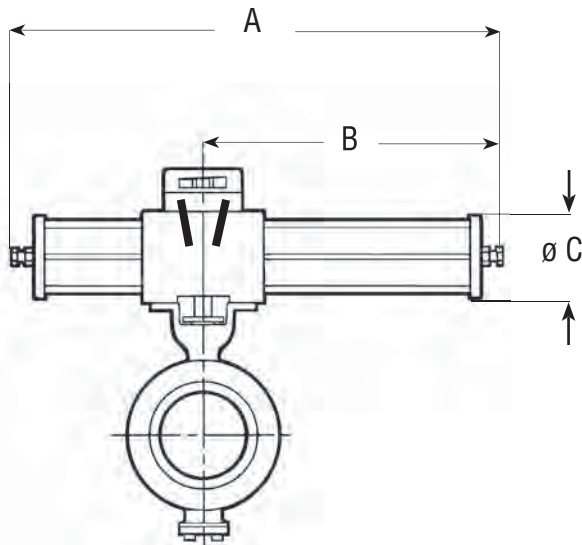

NAF 791292/791392

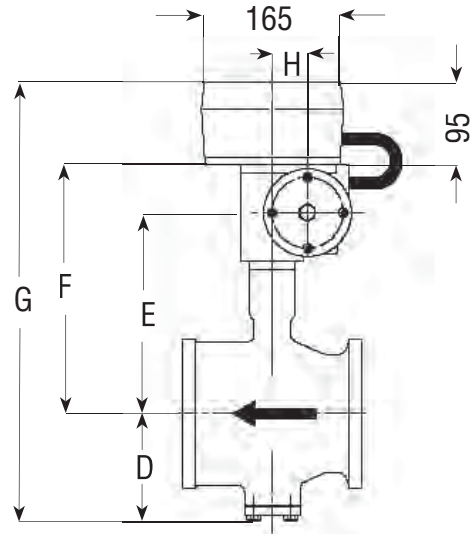

**NAF-Setball valves with pneumatic actuators (Table 7)**

The below stated dP apply for clean media type water.  
For other media contact NAF, see also page 4.

Size DN	Max. dp at supply of			NAF No.	Dimensions, mm								Mass kg <sup>2)</sup>
	4 bar	5 bar	6 bar		A	B	C	D	E	F	G <sup>1)</sup>	H	
<b>Single-acting, spring to close acc. to Fk 74.59</b>													
25	25	25	25	791292-0220	455	270	80	60	170	222	377	31	9
40	25	25	25	-0220	455	270	80	75	175	227	397	31	11
40	25	25	25	-1220	635	390	100	75	180	237	406	40	15
50	18	25	25	-0220	455	270	80	90	180	233	418	31	12
50	25	25	25	-1220	635	390	100	90	185	243	426	40	16
65	8	21	25	-0220	455	270	80	101	189	241	434	31	14
65	25	25	25	-1220	635	390	100	101	194	251	444	40	18
80	4	16	20	-0220	455	270	80	110	195	247	452	31	17
80	22	25	25	-1220	635	390	100	110	200	257	462	40	21
100	-	10	14	-0220	455	270	80	120	217	269	484	31	21
100	15	23	25	-1220	635	390	100	120	222	279	493	40	25
150	4	7	11	-1225	635	390	100	155	250	306	556	40	35
150	25	25	25	-2225	890	540	145	155	270	343	593	63	49
200	13	22	25	-2230	890	540	145	185	310	383	663	63	65
200	25	25	25	-3230	1050	640	200	185	336	436	716	75	85
250	6	10	14	-2235	890	540	145	230	370	443	768	63	123
250	24	25	25	-3235	1050	640	200	230	395	495	820	75	143
300	-	5	7	-2240	890	540	145	260	395	466	821	63	168
300	13	22	25	-3240	1050	640	200	260	420	520	875	75	188
350	6	13	18	-3250	1050	640	200	290	460	560	945	75	217
350	18	25	25	791392-4250	1520	965	260	290	490	620	1005	100	274
400	4	8	12	791292-3250	1050	640	200	308	483	613	1016	75	254
400	12	21	24	791392-4250	1520	965	260	308	513	643	1046	100	311
400	25	25	25	-5250	2210	1370	395	308	548	713	1116	150	696
500	-	6	10	791292-3250	1050	640	200	371	560	690	1156	75	391
500	9	16	20	791392-4250	1520	965	260	371	590	720	1186	100	448
500	20	20	20	791392-5250	2210	1370	395	371	625	790	1256	150	833

1) Including NAF valve positioner  
2) DN 25—200 Wafer version  
DN 250—500 Flanged version, PN 10.

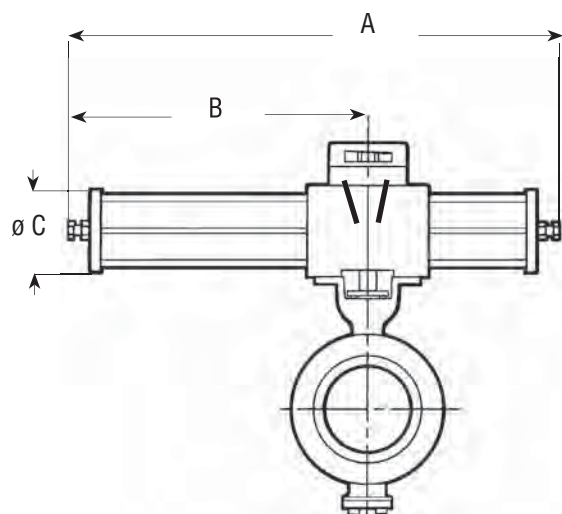

NAF 791294/791394

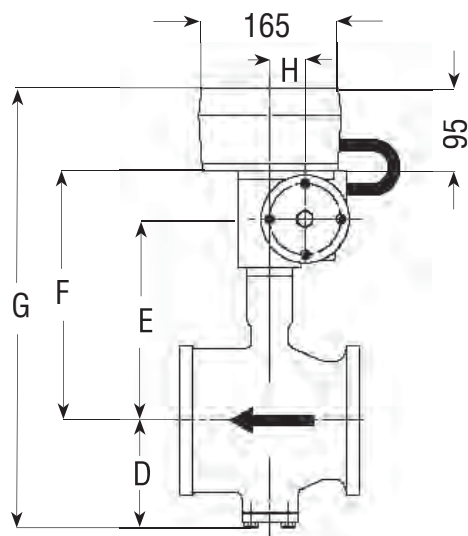

## NAF-Setball valves with pneumatic actuators (Table 8)

The below stated dP apply for clean media type water.  
For other media contact NAF, see also page 4.

Size DN	Max. dp at supply of			NAF No.	Dimensions, mm								Mass kg <sup>2)</sup>
	4 bar	5 bar	6 bar		A	B	C	D	E	F	G <sup>1)</sup>	H	
<b>Single-acting, spring to open acc. to Fk 74.59</b>													
25	20	25	25	791294-0220	455	270	80	60	170	228	383	31	9
25	25	25	25	-1220	635	390	100	60	175	232	387	40	13
40	14	25	25	-0220	455	270	80	75	175	232	402	31	11
40	25	25	25	-1220	635	390	100	75	180	236	406	40	15
50	11	25	25	-0220	455	270	80	90	180	237	422	31	12
50	25	25	25	-1220	635	390	100	90	185	241	426	40	16
65	4	17	23	-0220	455	270	80	101	189	241	434	31	14
65	14	25	25	-1220	635	390	100	101	194	251	444	40	18
80	-	11	11	-0220	455	270	80	110	195	247	452	31	17
80	9	25	25	-1220	635	390	100	110	200	257	462	40	21
100	6	18	24	-1220	635	390	100	120	222	278	493	40	25
100	25	25	25	-2220	890	540	145	120	242	315	530	63	39
150	-	5	8	-1225	635	390	100	155	250	306	556	40	35
150	13	25	25	-2225	890	540	145	155	270	343	593	63	49
200	5	17	22	-2230	890	540	145	185	310	383	663	63	65
200	21	25	25	-3230	1050	640	200	185	336	436	716	75	85
250	-	8	11	-2235	890	540	145	230	370	443	768	63	123
250	11	25	25	-3235	1050	640	200	185	336	436	820	75	143
300	-	4	6	-2240	890	540	145	260	395	466	821	63	168
300	6	18	18	-3240	1050	640	200	260	420	520	875	75	188
300	15	25	25	791394-4240	1520	965	260	260	448	580	935	100	245
350	-	6	11	791294-3250	1050	640	200	290	460	560	905	75	217
350	5	15	25	791394-4250	1520	965	260	290	490	620	1005	100	274
350	25	25	25	-5250	2210	1370	395	290	525	690	1075	150	659
400	-	10	18	-4250	1520	965	260	308	513	643	1046	100	311
400	17	25	25	-5250	2210	1370	395	308	548	713	1116	150	696
500	-	8	15	-4250	1520	965	260	371	590	720	1186	100	448
500	14	25	25	-5250	2210	1370	395	371	625	790	1256	150	833

1) Including NAF valve positioner

2) DN 25—200 Wafer version  
DN 250—500 Flanged version, PN 10.

### Accessories

NAF's pneumatic actuators, see data sheet Fk74.59 can be equipped with a large number of accessories.

The following are included in NAF's standard programme and are suitable for direct mounting to NAF pneumatic actuators.

### Valve positioner

Pneumatic and electro-pneumatic valve positioner, see data sheet Fk41.82.

Intelligent valve positioner, see data sheet Fk41.85.

### Solenoid valves

See data sheet Fk79.17.

### Electrical position indication

See data sheet Fk79.10.

### Terminal box

The actuator can be equipped with a junction box (part No. 349 20 930) of cast aluminium containing terminal blocks for connecting the solenoid valve and position sensors.

### Fugitive emissions Approval, EN ISO15848-1

NAF has certified some of our valves with a new stem sealing, according to EN ISO 15848-1 (this new standard will replace the old TA-luft standard). The packing box solution is with a V-ring set. The new packing set is live loaded with spring cups and equipped with an o-ring above the stem packing. Following valves have been certified in the first test.

Classification according to test results is

**ISO-FE BH - CC1 - SSA0 - t200°C PN25**

#### Classification classes:

BH Tightness class B, test fluid Helium  
CC1 20000 mechanical cycles, 2 thermal cycles.  
SSA0 Without shaft seal adjustments during test  
T200°C Temperature Class  
PN25 Endurance Class.

#### Certified Products

Wafer:

DN80-DN200

Flanged :

PN10 DN200 to DN300

PN16 DN80 to DN300

ANSI150 1" to 12"

PN25 DN200 to DN300

For other sizes and pressure classes contact NAF.

**Product code:** i.g 8780EB-0100-0B

Code	Seat sealing	Stem sealing
<b>B</b>	PTFE	Safeguard

**Other versions**

- **Stem seal in other materials**  
For temperatures up to 250°C the standard O-rings item 13 and 15 as per Fk 41.51GB can be replaced by PFM, Isolast®. For higher temperatures, contact NAF.  
*Product code K*
- **Degreased version for oxygen**  
Before assembly, all valve parts are degreased in trichlorethylene vapour. The valve is assembled and packaged so that no oil or grease will enter the valve.  
*Product code D*
- **Stem sealing for vacuum**  
For vacuum the stem sealing O-rings kit is turned to be tight against the pressure from the outside.  
For applications with alternating vacuum/overpressure is the overpressure limited to 2 bar.  
*Product code V*
- **Internal O-rings** for sealing the stem from the medium  
For media containing small, hard solid particles (such as those in flue gases, powders, granulates), and media which can crystallize in narrow slits. Those media can penetrate into the stem seal and give rise to increased actuating torque or increased wear.  
O-ring seals are arranged between the body and the body side of stem.  
*Product code I*
- **Explosive atmosphere according to Direktive 94/9/EC ATEX**  
NAF-Setball is certified according to ATEX 94/9/EC  II 2 G/D c  
*Product code: XA*
- **Fire-safe**
- **For flanges according to JIS 10K**
- **Enlarged outlet**
- **Titanium version**  
Contact NAF for further information.

**Product code NAF-Setball valves**

Example:

Code      87 8 0    E B    - 0100 - 02    D  
             1 2 3    4 5            6 7    (8)

**1. Valve type**

87 NAF-Setball

**2. Material**

8 Stainless steel

**3. Pressure rating**

Wafer version <sup>1)</sup>

	DIN	ANSI	
0	DN 150-200	Size 6"-8"	PN 10-16/ ANSI150
	DN 80-100	Size 3"-4"	PN 10-25/ ANSI150
	DN 25-65	Size 1"-2"	PN 10-40/ ANSI150-300
Flanged version			
2	PN 10		DN 200-500 <sup>2)</sup> (DN 80-150 choose PN 16)
3	PN 16		DN 80-500 <sup>2)</sup>
4	ANSI 150		Size 1"-20" <sup>3)</sup>
5	PN 25		DN 200-400 <sup>2)</sup> (DN 80-150 choose PN 40)
6	PN 40		DN 25-400
7	ANSI 300		Size 1"-16" <sup>3)</sup>

**4. Stem bearing**

	Body	Stem
E	Metaloplast bearing	-

**5. Body type**

B	Wafer
F	Flanged

1) The valve can be mounted between all flanges mentioned for respectively sizes. The mark plate on the DIN valves will include the highest pressure ratings in both PN and ANSI together with dimensions in both DN and size. Leakage test according to page 1. The ANSI valves are marked with the ANSI pressure class and size and are leakage tested according to ISA-75.19.01.

2) Size DN 25-65 have the same flange dimension in PN 10, 16, 25 and 40. Choose PN 40 for these valves.

3) Not available in size 2,5".

**6. Size**

DIN		ANSI	
wafer and flanged version DN		wafer and flanged version Size	
2505	25/5	1T05	1"/5
2510	25/10	1T10	1"/10
2515	25/15	1T15	1"/15
2520	25/20	1T20	1"/20
0040	40	01.5	1,5"
0050	50	0002	2"
0065	65	02.5	2,5"
0080	80	0003	3"
0100	100	0004	4"
0150	150	0006	6"
0200	200	0008	8"
0250	250	0010	10"
0300	300	0012	12"
0350	350	0014	14"
0400	400	0016	16"
0500	500	0020	20"

**7. Seals**

	Seat	Seat seal	Stem seal	Max.Temp.
0A	Alloy 6	PTFE	Zebra-CL™	250°C
0B	Alloy 6	PTFE	Safeguard	250°C
01	Alloy 6	PTFE	EPDM	200°C
02	Alloy 6	EPDM	EPDM	150°C
05	Alloy 6	PTFE	FPM	200°C
06	Alloy 6	FPM	FPM	150°C
07	Alloy 6	PTFE	Graphite	250°C
1A	PTFE	PTFE	Zebra-CL™	225°C
1B	PTFE	PTFE	Safeguard	225°C
11	PTFE	PTFE	EPDM	200°C*
12	PTFE	EPDM	EPDM	150°C*
15	PTFE	PTFE	FPM	200°C*
16	PTFE	FPM	FPM	150°C*
17	PTFE	PTFE	Graphite	225°C*

\*See Pressure, temperature diagram

**8. Other versions**

<b>D</b>	Degreased version for oxygen
<b>I</b>	Internal O-rings for sealing the stem from the medium
<b>K</b>	Stem seal in Isolast
<b>V</b>	Stem sealing for vacuum
<b>XA</b>	ATEX certified

