

Primary characteristics

NAF-Duball is a full-bore ball valve which, due to its design and combination of materials, is equally suitable for use as control valve, on/off control valve or shut-off valve. The NAF-Duball is supplied as standard in stainless steel. Also available in other materials e.g. Hastelloy C.

The valve has:

- an easy-to-service arrangement, due to the off-center joint face of the valve body, which allows for easy replacement of the ball and seals, without the need for removing the stem and actuator.
- a floating ball that seals in both directions of flow and at low differential pressures. For tight valve at differential pressures below 0,5 bar consult NAF.
- sturdy, blowout-proof rigidly journalled stem and a drive arrangement between the ball and stem that transmits torque evenly
- stem seal with maintenance-free O-ring seals or stuffing box
- metal-to-metal Alloy 6 seat rings or soft, enclosed carbon reinforced PTFE seat rings.
- a range of materials available for the ball
- a wide range of optional versions, over and above those described in the catalogue sheet
- the NAF standard for mounting the actuator, which simplifies installation and results in a compact valve/actuator unit.

CE-marked according to Pressure Equipment Directive (PED 97/23/EG) module H, category III.
For module H1, category IV contact NAF

Applications

NAF-Duball can be used both as a control valve and as a shut-off valve, in a wide variety of applications and in different operating modes. The valve represents a concrete result of our product philosophy which is focused on functionality, high quality and low life cycle costs, and is based on concentrating our range to a limited number of valve types, but all of them suitable for a wide variety of applications.

The excellent characteristics of NAF-Duball are particularly beneficial under the most arduous operating conditions in the process industry, where difficult media and demanding pressure conditions make severe demands on the design, materials and performance.

NAF-Duball is recommended for applications in the following branches:

- Pulp and Paper
- Chemical and Petro Chemical
- Oil and gas
- Power stations
- Steel works



Technical specification for standard design

Material:	EN 1.4408
Size range:	DN 25—400 (1"—16")
Pressure ratings:	PN 10—40 ANSI Class 150—300
Face-to face lengths:	PN 10: EN 558-1 series 12 (SSG 1042) ANSI 150: ANSI B 16.10 Class 150 long PN 25—40: EN 558-1 series 4 (SSG 1043) ANSI 300: ANSI B 16.10 Class 300 short Size 1"—12" Class 300 long Size 14"—16"
Valve design:	ANSI B16.34 och EN 12 516
Installation method:	Flanges to DIN or ANSI B 16.5
Temperature range:	-30 - 350°C, see graph on page 2
Test pressure:	1,5xPN with valve open 1,1xPN with valve closed
Sealing class:	Testing medium is water. PTFE seats EN 12266-1 Rate A Metal seats IEC 534-4 Class V ANSI / FCI70-2

At request for test fluid air contact NAF for more information

Working pressure, differential pressure and temperature

The maximum working pressure and temperature in the body depends on pressure class according to respectively flange standards. For EN1092-1:2001 see the diagram. The differential pressure when the valve is closed is 25 bar, and the temperature dependence is shown in the diagram on page 3. The stem gland with EPDM O-ring can be used for temperatures up to 200°C. The standard design of stem gland with stuffing box and graphite packing and stem bushings in Stellite can be used for temperatures up to 350°C. For higher temperatures, consult NAF.

Max. Working Pressure PN Valves

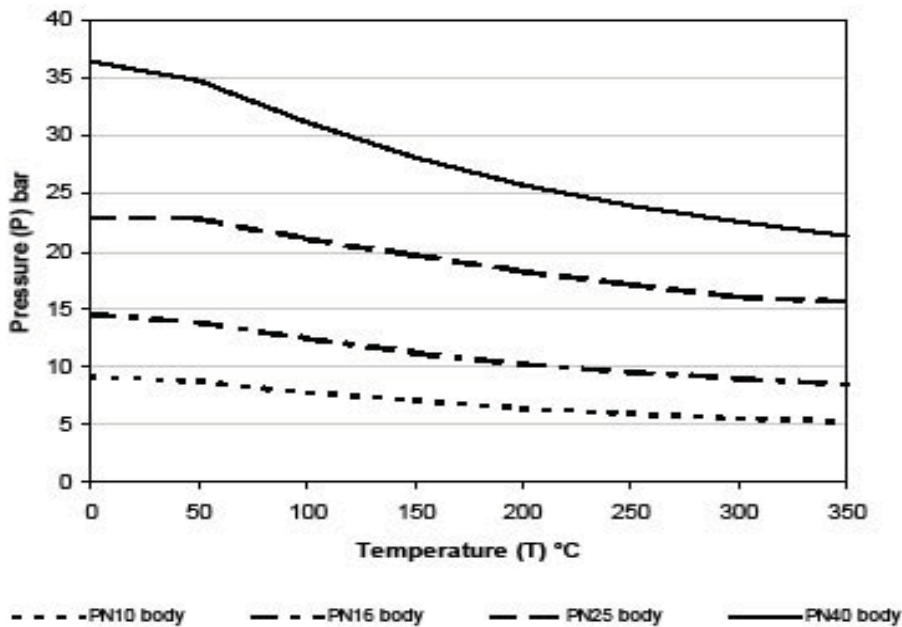

Max. Working Pressure ANSI valves

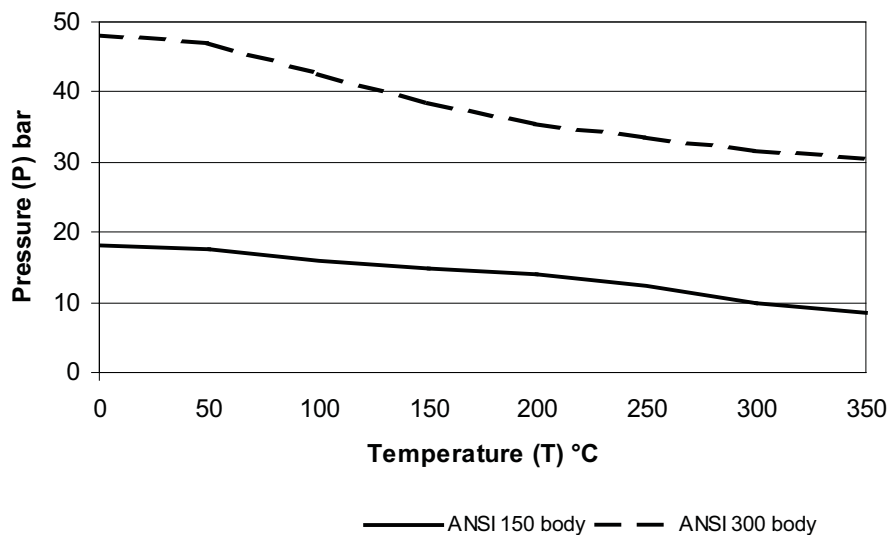

Max. dp

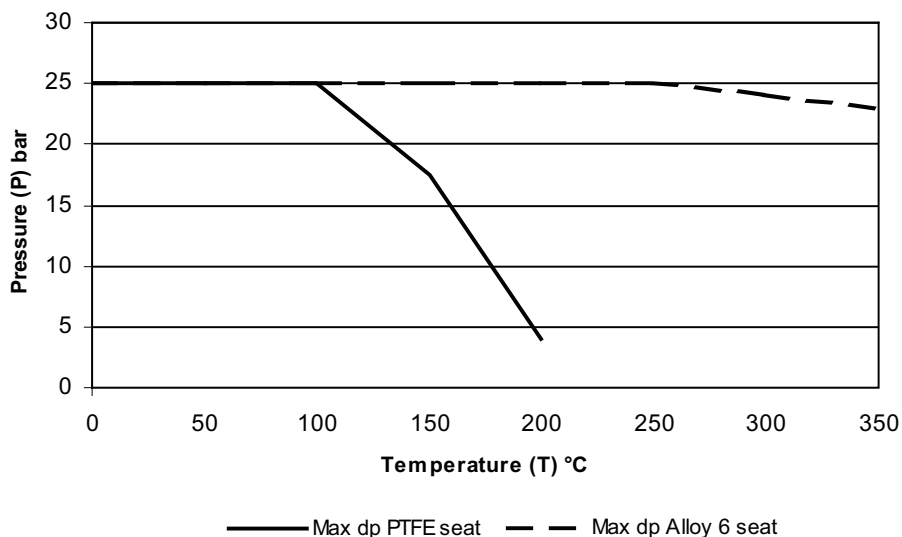

Flow capacities and characteristics (Table 1)

DN	Size	K _v at an opening angle of															
		15°	20°	25°	30°	35°	40°	45°	50°	55°	60°	65°	70°	75°	80°	85°	90°
25	1	0	1	1	2	2	3	4	5	7	9	12	16	22	31	45	63
40	1.5	0	2	3	4	6	8	11	14	18	24	31	40	55	79	116	160
50	2	1	3	4	6	9	13	17	21	28	37	48	63	86	123	182	250
65	-	1	5	7	11	16	21	28	36	48	63	81	106	145	209	307	423
80	3	2	7	11	16	24	32	42	55	72	95	122	161	220	316	466	640
100	4	3	11	17	26	37	50	66	86	113	149	191	251	344	494	728	1000
125	-	5	17	26	40	58	78	103	134	176	232	199	393	538	771	1137	1563
150	6	7	24	38	58	84	113	149	193	254	334	430	565	775	1111	1637	2250
200	8	12	43	67	103	149	200	265	343	451	594	765	1005	1377	1975	2910	4000
250	10	19	67	105	160	233	313	441	535	705	929	1195	1570	2150	3086	4547	6250
300	12	27	97	151	231	335	450	596	771	1015	1337	1721	2261	3098	4444	6548	9000
350	14	37	132	205	315	456	613	811	1049	1381	1820	2343	3078	4217	6048	8912	12250
400	16	48	172	268	411	596	800	1059	1370	1804	2377	3060	4020	5508	7900	11640	16000

Note: For sizes > DN400 see NAF-Trunnball Fk 41.66
 $C_v = 1,16 \times K_v$

Materials (Table 2)

Item	Qty	Part	Material
1	1	Body	EN 1.4408/CF8M
2	1	Body	EN 1.4408/CF8M
3	1	Ball	EN 1.4408/CF8M
4*	2	Seat ring	PTFE carbon reinforced 10%
5	1	Stem assembly	EN 1.4460
6	1	Circlip	Spring steel
7	1	Backing ring	PTFE
8	1	Washer	A4
9	**	Screw	A4
10*	1	Backing ring	PTFE
11*	2	O-ring	EPDM
12*	2	Bushing	PTFE carbon reinforced
13*	1	Anti-friction washer	PTFE carbon reinforced
14*	1	Seal ring	PTFE
15	1	Bolt	A4
16	1	Nut	A4
17	1	Stud	A4
18	2	Key	A4
19	1	Ball	EN 1.4408/CF8M hard chrome plated
20	1	Ball	Alloy 6
21	2	Seat ring	SS/Alloy 6
22*	2	Seat seal	PTFE carbon reinforced
23	1	Gland cover	EN 1.4408/CF8M
24*	1	Boxpacking	Graphite
25	2	Bolt	A4
26	2	Nut	A4
27	1	Split ring	EN 1.4436
28	1	Ring	Alloy 6
29	2	Bushing	Alloy 6
30*	1	Seal ring	Graphite
31*	2	Seal ring	Graphite
32	1	Stem extension	EN 1.4460
33	2	Actuator yoke	Zink plated steel
34	1	Stop screw	A4

* Recommended spare parts

** Qty depends on the DN.

Items 23—34 are for the stuffing box version for 350°C. Material combinations others than those specified are available to order - consult your NAF representative.

Seat ring

Alloy 6 seat

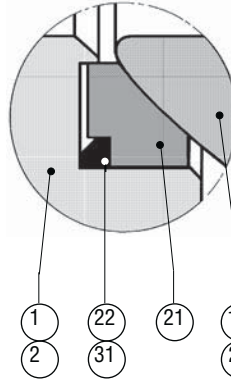

PTFE-seat

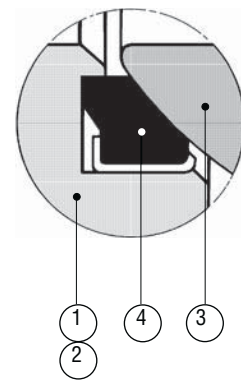

O-ring version

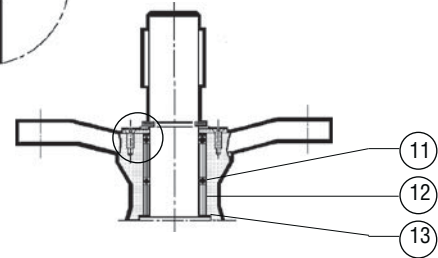
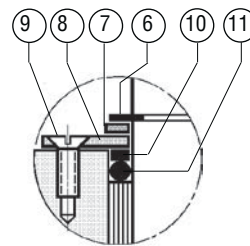

Packing box version

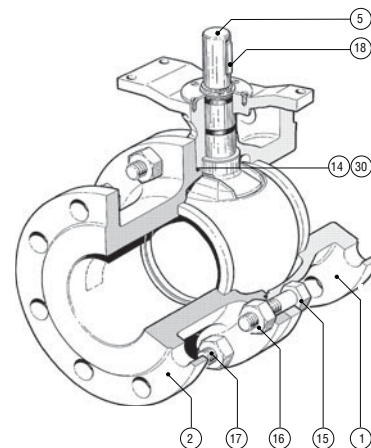
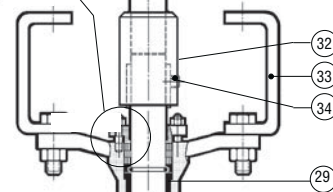
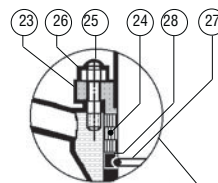

Operating torque, Nm (Table 3)

DN	Differential pressure in bar									
	5		10		16		20		25	
	PTFE	Alloy 6	PTFE	Alloy 6	PTFE	Alloy 6	PTFE	Alloy 6	PTFE	Alloy 6
25	12	15	16	20	19	23	22	30	25	35
40	16	20	23	28	30	36	35	42	40	50
50	20	25	30	36	40	48	48	60	60	70
65	30	36	50	60	75	85	85	105	110	130
80	55	65	90	110	130	160	160	200	200	240
100	95	115	160	190	250	280	300	350	350	450
125	180	210	320	390	480	550	530	690	680	850
150	300	350	530	620	750	950	920	1150	1100	1400
200	750	930	1350	1600	1900	2400	2380	2900	2900	3500
250	1500	1750	2500	3000	3600	4500	4400	5400	5200	6500
300	2400	3200	4000	5100	6000	7500	7200	9000	9000	11000
350	3800	4500	6400	8000	10000	12000	11500	14500	14500	18000
400	5500	7000	9700	12000	15000	18000	18000	22000	22000	26000

Operating torque

The minimum design differential pressure for selecting the actuator is 5 bar. The specified torques in the table above are for clean media. For steam and with Stellite seat rings increases the required torque with factor 1.5. If the media contains solids, if it is a suspension, etc., consult NAF.

Sizing of control valves

We have a user friendly valve calculation program which can be ordered through your NAF representative. The program is based on calculating formula according to the standards IEC 60534 and ISA S75.01.

Dimensions and mass

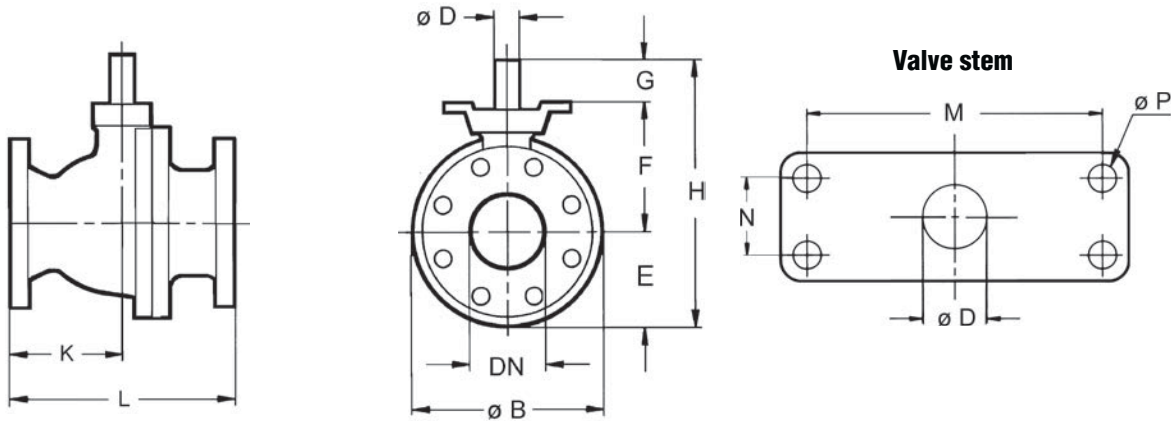

(Table 4)

Size DN	B	D	E	F	G	H	K PN10	L PN10	K PN25	L PN25	K PN40	L PN40
25 1"	124	16	62	83	38	183	1)	1)	2)	2)	66	165
40 1,5"	150	16	75	91	38	204	1)	1)	2)	2)	95	190
50 2"	165	20	83	106	43	232	1)	1)	2)	2)	108	216
65 -	185	25	93	113	50	256	111	222	2)	2)	121	241
80 3"	214	25	107	137	50	284	121	241	2)	2)	142	283
100 4"	244	25	122	152	50	324	153	305	2)	2)	153	305
125 -	290	35	145	179	65	389	178	356	2)	2)	191	381
150 6"	336	40	168	218	80	466	197	394	2)	2)	202	403
200 8"	452	50	226	268	93	587	229	457	251	502	251	502
250 10"	528	60	264	321	111	696	267	533	284	568	284	568
300 12"	622	70	311	379	131	821	305	610	324	648	324	648
350 14"	688	90	344	467	172	983	343	686	381	762	381	762
400 16"	767	100	384	518	190	1092	381	762	419	838	419	838

(Table 5)

Size DN	K	L	K	L	M	N	P	Mass, kg				
	ANSI 150		ANSI 300					PN 10	PN 25	PN 40	ANSI 150	ANSI 300
25 1"	52	127	66	165	115	30	11	1)	2)	9	9	10
40 1,5"	60	165	95	190	115	30	11	1)	2)	11	11	12
50 2"	74	178	108	216	115	30	11	1)	2)	14	13	14
65 -	-	-	-	-	115	30	11	17	2)	19	-	-
80 3"	102	203	142	283	115	30	11	23	2)	27	23	30
100 4"	107	229	153	305	115	30	11	33	2)	36	36	43
125 -	-	-	-	-	160	40	14	53	2)	61	-	-
150 6"	197	394	202	403	214	60	18	74	2)	81	75	91
200 8"	229	457	210	419	214	60	18	124	144	154	127	148
250 10"	267	533	229	457	214	60	18	197	222	241	203	232
300 12"	305	610	251	502	277	115	33	298	334	364	316	340
350 14"	343	686	381	762	277	115	33	422	504	539	437	542
400 16"	381	762	419	838	277	115	33	570	668	728	591	716

1) For PN 10 in sizes DN 25-50 see PN40
 2) For PN 25 in sizes DN 25-150 see PN 40

Actuators

NAF-Duball is available with hand levers or with pneumatic or electric actuators and accessories.

Use the following tables for selecting the hand levers and standard pneumatic actuators. For clean media type water 20 °C.

If other pneumatic or electric actuators are required, consult your NAF representative.

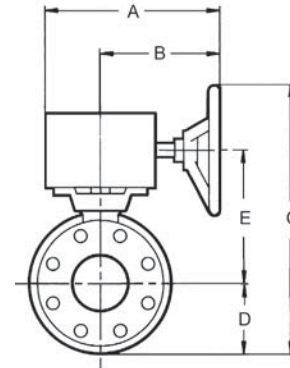
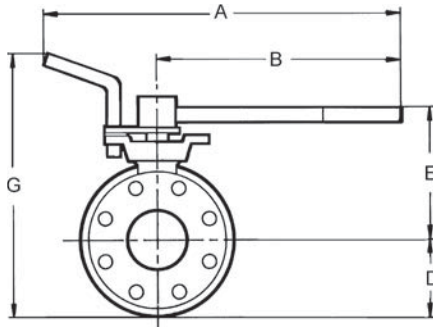

NAF-Duball valves with hand levers (Table 6)

Size DN	Max. dp bar Seat of		NAF No.	Dimensions, mm					Mass kg ¹⁾
	PTFE	Alloy 6		A	B	D	E	G	
Hand lever as per Fk 70.51									
25	25	25	791020-1	500	350	62	121	265	11
40	25	25	-1	500	350	75	129	286	13
50	25	25	-2	500	350	83	144	309	16
65	25	25	-3	500	350	93	161	335	21
80	15	13	-3	500	350	107	185	374	29
100	10	8	-3	615	450	122	200	404	38
Worm gear actuator as per Fk 70.76 ²⁾									
25	25	25	791051-11016	249	174	62	117	279	13
40	25	25	791051-11016	249	174	75	125	300	15
50	25	25	791051-11020	249	174	83	140	323	18
65	25	25	791051-11025	249	174	93	147	340	23
80	25	25	791051-11025	249	174	107	171	378	31
100	25	25	791051-11025	249	174	122	186	408	40
125	25	25	791051-22035	328	243	145	222	517	70
150	25	25	791051-33040	416	291	168	268	636	98
200	16	12	791051-33050	416	291	226	333	759	161
200	25	25	791051-43050	507	337	226	323	799	176
250	18	14	791051-43060	507	337	264	376	890	254
250	25	25	791051-53060	591	421	264	376	840	260
300	17	12	791051-55070	591	421	311	459	970	372
300	25	25	791051-65070	697	487	311	468	1079	401
350	20	16	791051-65090	697	487	344	591	1235	571
350	25	23	791051-75090	747	537	344	591	1235	585
350	25	25	791051-85090	848	593	344	552	1246	696
400	13	10	791051-65100	697	487	384	657	1341	735
400	17	14	791051-75100	747	537	384	657	1341	749
400	25	25	791051-85100	848	593	384	628	1362	860

1) Applies to actuator + PN 25 valve

2) Available with locking device - please contact NAF

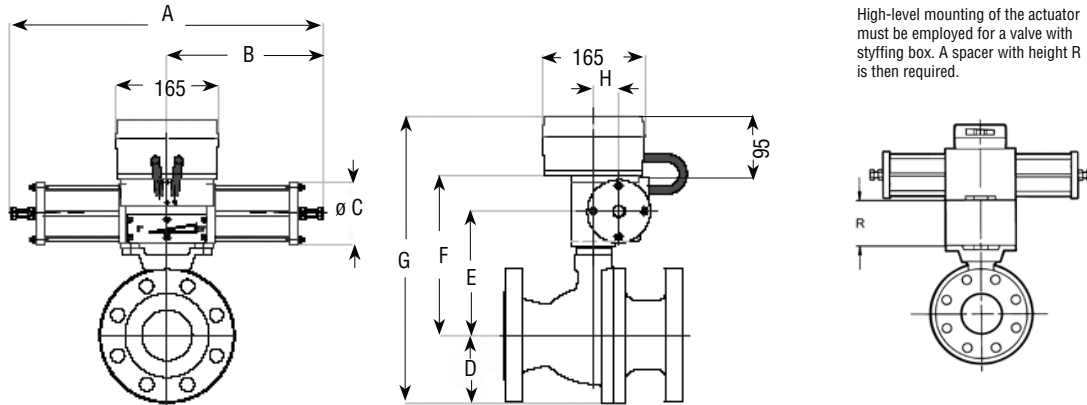

NAF 791290/791390

NAF-Duball valves with pneumatic actuators (Table 7)

The below stated dP apply for clean media type water 20 °C. For other media contact NAF, see also page 5.

Size DN	Max. dP bar at supply of						NAF No.	Dimensions, mm								Mass kg ¹⁾	
	4 bar		5 bar		6 bar			A	B	C	D	E	F	G ²⁾	H		R
	PTFE	Alloy 6	PTFE	Alloy 6	PTFE	Alloy 6											
Double-acting as per Fk74.59																	
25	25	25	25	25	25	25	791390-0216	370	185	80	62	134	185	342	31	70	15
40	25	25	25	25	25	25	-0216	370	185	80	75	142	193	363	31	70	17
50	25	25	25	25	25	25	-0220	370	185	80	83	157	208	386	31	70	18
65	18	15	25	19	25	25	-0225	370	185	80	93	164	215	403	31	70	23
65	25	25	25	25	25	25	791290-1225	490	245	100	93	169	225	413	40	70	25
80	9	7	11	9	19	12	791390-0225	370	185	80	107	188	239	441	31	70	31
80	20	16	25	21	25	25	791290-1225	490	245	100	107	193	249	451	40	70	33
80	25	25	25	25	25	25	-2125	700	350	145	107	212	285	487	63	70	44
100	-	-	5	-	7	5	791390-0225	370	185	80	122	203	254	471	31	70	40
100	10	8	13	11	17	13	-1225	490	245	100	122	208	264	481	40	70	42
100	22	17	25	24	25	25	-2125	700	350	145	122	227	300	517	63	70	53
125	10	8	13	11	17	13	-2135	700	350	145	145	254	327	567	63	80	78
125	23	19	25	25	25	25	-2235	700	350	145	145	254	327	567	63	80	78
150	5	-	7	6	9	8	-2140	700	350	145	168	293	366	629	63	120	98
150	13	10	17	13	21	16	-2240	700	350	145	168	293	366	629	63	120	98
150	25	22	25	25	25	25	-3240	820	410	200	168	318	410	673	75	120	110
200	8	6	10	8	13	10	-3150	820	410	200	226	368	460	781	75	120	173
200	17	13	21	17	25	21	-3250	820	410	200	226	368	460	781	75	120	173
200	25	25	25	25	25	25	791390-4250	1110	555	260	226	396	499	820	100	120	189
250	8	6	10	8	12	10	-4160	1110	555	260	264	449	552	911	100	120	267
250	18	14	23	18	25	22	-4260	1110	555	260	264	449	552	911	100	120	267
250	25	25	25	25	25	25	-5160	1600	800	395	264	503	651	1010	150	120	442
300	-	-	5	-	7	5	-4170	1110	555	260	311	543	646	1052	100	150	379
300	10	7	13	10	16	12	-4270	1110	555	260	311	543	646	1052	100	150	379
300	22	17	25	23	25	25	-5170	1600	800	395	311	561	709	1115	150	150	554
300	25	25	25	25	25	25	-5270	1600	800	395	311	561	709	1115	150	150	554
350	13	10	16	13	21	17	-5190	1600	800	395	344	649	797	1236	150	150	724
350	25	22	25	21	25	25	-5290	1600	800	395	344	649	797	1236	150	150	724
400	8	5	10	8	13	10	-5100	1600	800	395	384	700	848	1327	150	150	888
400	18	14	22	18	24	23	-5200	1600	800	395	384	700	848	1327	150	150	888

1) Applies to actuator + PN 25 valve
2) Including NAF valve positioner

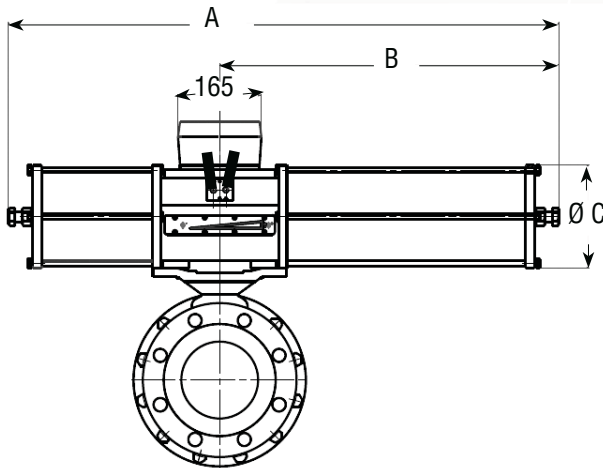

NAF791292/791392

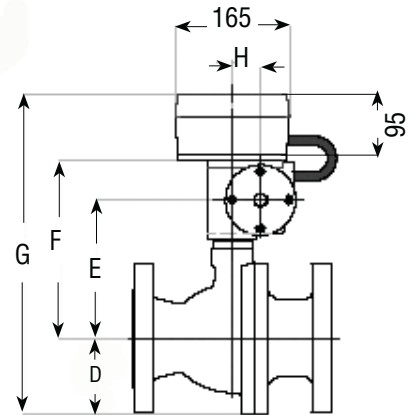

(Table 8a)

The below stated dP apply for clean media type water 20 °C.
For other media contact NAF, see also page 5.

Size DN	Max dP bar at supply of						NAF No.	Dimensions, mm									Mass kg ¹⁾
	4 bar		5 bar		6 bar			A	B	C	D	E	F	G ²⁾	H	R	
	PTFE	Alloy 6	PTFE	Alloy 6	PTFE	Alloy 6											
Single-acting, spring to close as per Fk 74.59																	
25	25	20	25	25	25	25	791392-0216	455	270	80	62	134	185	342	31	70	14
40	16	12	25	22	25	25	-0216	455	270	80	75	142	193	363	31	70	16
40	25	25	25	25	25	25	791292-1216	635	390	100	75	147	203	373	40	70	20
50	10	8	18	15	25	20	791392-0220	455	270	80	83	157	208	386	31	70	19
50	25	25	25	25	25	25	791292-1220	635	390	100	83	162	218	396	40	70	23
65	16	13	25	25	25	25	-1225	635	390	100	93	169	225	413	40	70	28
80	8	6	15	12	19	12	-1225	635	390	100	107	193	249	451	40	70	36
80	25	25	25	25	25	25	-2225	890	540	145	107	212	285	487	63	70	50
100	-	-	8	6	10	6	-1225	635	390	100	122	208	264	481	40	70	45
100	20	16	25	25	25	25	-2225	890	540	145	122	227	300	517	63	70	59
125	9	7	17	14	22	14	-2235	890	540	145	145	254	327	567	63	80	84
125	25	25	25	25	25	25	-3235	1050	640	200	145	285	377	617	75	80	104
150	5	-	10	8	12	8	-2240	890	540	145	168	293	366	629	63	120	104
150	25	20	25	25	25	25	-3240	1050	640	200	168	318	410	673	75	120	124
150	25	25	25	25	25	25	791392-4240	1520	965	260	168	346	449	712	100	120	181
200	8	6	13	8	17	8	791292-3250	1050	640	200	226	368	460	781	75	120	187
200	14	11	25	22	25	22	791392-4250	1520	965	260	226	396	499	820	100	120	244
250	6	5	14	10	17	10	-4260	1520	965	260	264	449	552	911	100	120	322
250	25	25	25	25	25	25	-5260	2210	1370	395	264	503	651	1010	150	120	687
300	-	-	7	5	9	5	-4270	1520	965	260	311	543	646	1052	100	150	434
300	25	19	25	25	25	25	-5270	2210	1370	395	311	561	709	1115	150	150	800
350	14	11	22	18	25	18	-5290	2210	1370	395	344	649	797	1236	150	150	969
400	9	6	14	11	17	11	-5200	2210	1370	395	384	700	848	1327	150	150	1133

1) Applies to actuator + PN 25 valve

2) Including NAF valve positioner

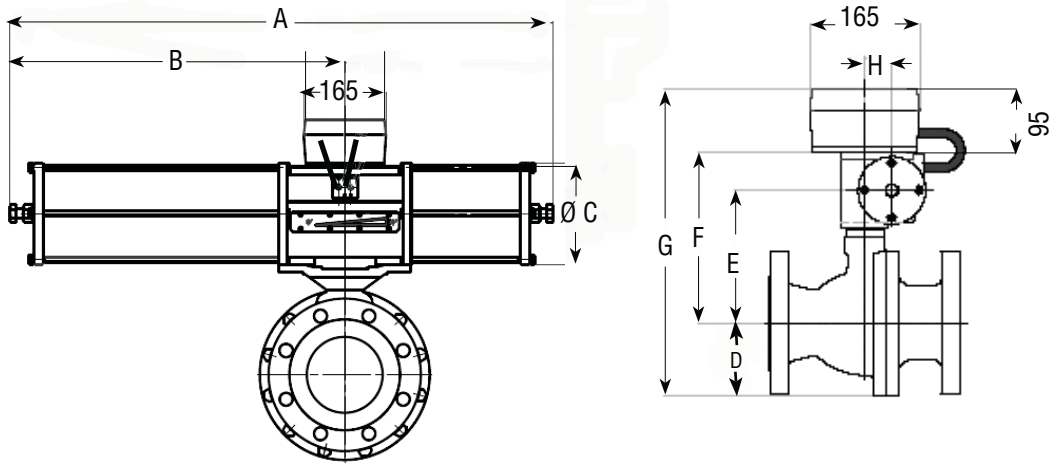

NAF791294/791394

(Table 8b)

The below stated dP apply for clean media type water 20 °C.
For other media contact NAF, see also page 5.

Size DN	Max dP bar at supply of						NAF No.	Dimensions, mm										Mass kg ¹⁾
	4 bar		5 bar		6 bar			A	B	C	D	E	F	G ²⁾	H	R		
	PTFE	Alloy 6	PTFE	Alloy 6	PTFE	Alloy 6												
Single-acting, spring to open as per Fk 74.59																		
25	6	-	25	25	25	25	791394-0216	455	270	80	62	134	185	342	31	70	14	
40	-	-	20	15	25	25	-0216	455	270	80	75	142	193	363	31	70	16	
40	25	17	25	25	25	25	791294-1216	635	390	100	75	147	203	373	40	70	20	
50	-	-	12	9	22	18	791394-0220	455	270	80	83	157	208	386	31	70	19	
50	25	12	25	25	25	25	791294-1220	635	390	100	83	162	218	396	40	70	23	
65	10	5	25	19	25	22	-1225	635	390	100	93	169	225	413	40	70	28	
65	25	25	25	25	25	25	-2225	890	540	145	93	188	261	449	63	70	42	
80	5	-	16	9	16	13	-1225	635	390	100	107	193	249	451	40	70	36	
80	25	14	25	25	25	25	-2225	890	540	145	107	212	285	487	63	70	50	
100	-	-	8	-	8	7	-1225	635	390	100	122	208	264	481	40	70	45	
100	8	7	25	22	25	25	-2225	890	540	145	122	227	300	517	63	70	59	
100	25	14	25	25	25	25	-3225	1050	640	200	122	252	344	561	75	70	79	
125	6	-	19	11	19	16	-2235	890	540	145	145	254	327	567	63	80	84	
125	23	14	25	25	25	25	-3235	1050	640	200	145	285	377	617	75	80	104	
150	-	-	10	6	10	9	-2240	890	540	145	168	293	366	629	63	120	104	
150	13	8	25	23	25	25	-3240	1050	640	200	168	318	410	673	75	120	124	
150	22	12	25	25	25	25	791394-4240	1520	965	260	168	346	449	712	100	120	181	
200	-	-	14	8	14	11	791294-3250	1050	640	200	226	368	460	781	75	120	187	
200	7	-	25	16	25	25	791394-4250	1520	965	260	226	396	499	820	100	120	242	
200	25	25	25	25	25	25	-5250	2210	1370	395	226	450	598	919	150	120	609	
250	-	-	16	8	16	12	-4260	1520	965	260	264	449	552	911	100	120	322	
250	21	12	25	25	25	25	-5260	2210	1370	395	264	503	651	1010	150	120	687	
300	-	-	8	-	8	6	-4270	1520	965	260	311	543	646	1052	100	150	433	
300	11	6	25	22	25	25	-5270	2210	1370	395	311	561	709	1115	150	150	800	
350	6	-	24	13	24	19	-5290	2210	1370	395	344	649	797	1236	150	150	969	
400	-	-	15	8	15	12	-5200	2210	1370	395	384	700	848	1327	150	150	1133	

1) Applies to actuator + PN 25 valve

2) Including NAF valve positioner

Accessories

NAF's pneumatic actuators, see data sheet Fk74.59 can be equipped with a large number of accessories. The following are included in NAF's standard programme and are suitable for direct mounting to NAF pneumatic actuators.

Valve positioner

Pneumatic and electro-pneumatic valve positioner, see data sheet Fk41.82. Intelligent valve positioner, see data sheet Fk41.85.

Solenoid valves

See data sheet Fk79.17.

Filter regulator

Can be delivered (part no. 79-SMC-AW20K-F02CE-C).

Electrical position indication

See data sheet Fk79.10.

Terminal box

The actuator can be equipped with a junction box (part No. 349 20930) of cast aluminium containing terminal blocks for connecting the solenoid valve and position sensors.

Other versions

- **Locked seat rings**, all valves manufactured after 980101 are prepared for locking of the seat rings in the form of peening-over as shown in fig. 1.

Product code: L

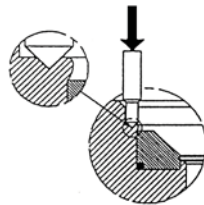

Fig. 1

- **Degreased for oxygen**, all components of the valve are degreased before assembly. A special grease which is approved for oxygen is used in assembly.

Product code: D

- **Sealed seat rings**, seat rings with two EPDM O-rings to prevent media to penetrate behind seat ring shown in fig. 2. Used with media that crystallize. Max. temp 130°C.

At higher temperature, contact NAF.

Product code: T

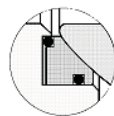



Fig. 2

- **Explosive atmosphere according to Directive 94/9/EC ATEX**

NAF-Duball is certified according to ATEX 94/9/EC 

II 2 G/D c
Product code: XA

- **Straight cylindrical flow path**

DN 25-150 in design -25, -95 and -96 and DN 25-65 in design -27 and 97 have a straight cylindrical flow path. DN up to 300 can be designed with a cylindrical flow path, whereas DN 350-400 are provided with a reinforced ball, since an entirely cylindrical flow path in these sizes would be too heavy. Used for applications such as blow-down and discharge valves.

Product code: C

- **O-ring or springs behind the seat rings**

If the differential pressure is low (below 0,5 bar) and a specified tightness must be maintained, O-rings or springs must be fitted behind the seat rings.

Product code: E (O-ring in EPDM or FPM if the stem sealing M (FPM) is selected) max 130°C

W (Wave spring) max 165°C

- O-rings or springs behind the seat rings
- Tappings for flushing or drainage
- Seat ring with scraper edge
- Stem seal of FPM or PFM (Isolast)
- Flanges to DIN 2512, Form N or DIN 2513, Form R
- Alloy 6-lined inlet and outlet
- Fire-Safe
- Anti-static
- Other material

CG8M	code 88E...
CF3M	code 88G...
CG3M	code 88F...
Duplex EN 1.4470	code 88D...
Hastelloy C	code 88H...
Monel	code 88M...
254 SMO	code 88S...
Carbon steel	code 886...

Contact NAF for further information

Product code NAF-Duball valves

Example:

	<u>88</u>	<u>8</u>	<u>6</u>	<u>9</u>	<u>7</u>	-	<u>0150</u>
Code	1	2	3	4	5		6

1. Valve type
88 Ball valve

2. Material (Body) ¹⁾
8 1.4408 / CF8M

3. Pressure rating

2 PN 10	(DN 65 — 400) ²⁾
4 ANSI Class 150	(Size 1" — 16")
5 PN 25	(DN 200 — 400) ²⁾
6 PN 40	(DN 25 — 400)
7 ANSI Class 300	(Size 1" — 16")

4. Stem seal

2	Graphite stuffing box, up to 350°C ³⁾
9	EPDM O-ring, up to 200°C

5. Seals

	Ball	Seat ring
5	EN1.4408 / CF8M hard chromium-plated	Alloy 6
6	EN1.4408 / CF8M	PTFE, carbon reinforced
7	Alloy 6	Alloy 6

6. Size

EN version	DN	ANSI version	Size
0025	25	0001	1"
0040	40	01.5	1.5"
0050	50	0002	2"
0065 ⁴⁾	65	-	-
0080	80	0003	3"
0100	100	0004	4"
0125 ⁴⁾	125	-	-
0150	150	0006	6"
0200	200	0008	8"
0250	250	0010	10"
0300	300	0012	12"
0350	350	0014	14"
0400	400	0016	16"

¹⁾ Other materials see page 11.

²⁾ Size 25—50 has the same flange dimensions in PN 10, 16, 25 and 40. Choose PN 40 for these sizes.
Size 65—150 has the same flange dimensions in PN 25 and 40. Choose PN 40 for these sizes.

³⁾ Stuffing box version includes stem extension and actuator yoke.

⁴⁾ DN 65 and 125 contact NAF

