

Primary characteristics

NAF-Navalball is a one-piece, all-welded, soft-seated on/off-valve. The valve is made of carbon steel and is available in pressure classes PN16, 25, 40 in dimensions DN 10-250.

The valve has/is:

- one-piece welded design with no body joints to leak
- low lifetime cost, due to long life, high leakage-tight integrity, and low initial cost
- easy to insulate, because of the long, circular stem housing
- easy to retrofit actuating equipment

CE-marked according to PED97/23/EG, module H.



Design

The valve body, end pieces and valve neck are welded together to form a single unit and the blow-out proof stem is sealed by means of two FPM O-rings, the upper one of which is replaceable (both in DN65-DN250).

The PTFE thrust washer between the stem shoulder and valve neck prevents jamming and protects the stem seal from the media. Bevel spring washers keep the seal pressed against the ball to ensure that the valve remains leak-tight regardless of pressure fluctuations.

Applications

NAF-Navalball in carbon steel are suitable for district heating (CHP) installations, heat transfer piping, oil lines, oxygen-free water lines and other liquids and gases which do not attack the valve.

Connections

The valve can be made with different ends, butt welded, female threads, flange ends and a combination between butt-welded / female thread ends.

Technical specification

Material:	Carbon steel
Dimension:	DN 10 - 250
Pressure class:	PN 16 - 40
Temperature range:	-20 to +200°C
Face-to-face:	See table 2-3
Connections:	Welded ends, flange or internal thread

Working pressure and temperature

bar(e)

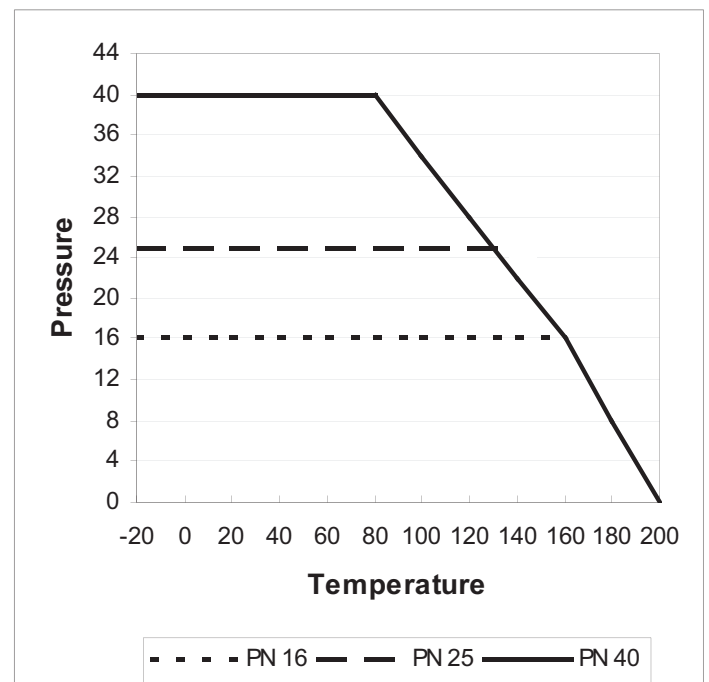

Material specification

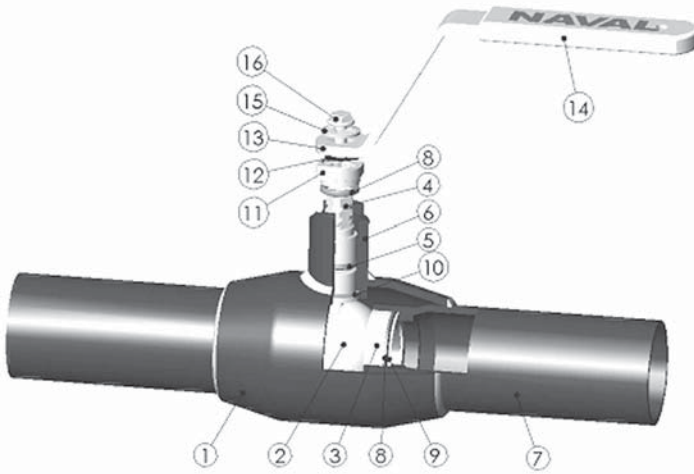

(Table 1)

Item	Description	Material
1	Body	P235GH (1.0345)
2	Ball	AISI 304
3	Seat ring	PTFE+C
4	Stem	AISI 303
5	O-ring	FPM
6	Stem housing	P355NH (1.0565)
7	Weld ends	P235GH (1.0345)
8	Washer	AISI 316
9	Bevel washer	C67 DIN 17222
10	Thrust washer	PTFE
11	Washer	AISI 304
12	Washer	CK75 DIN 17222
13	Lever	Zinc-plated steel
14	Handle	Plastic
15	Washer	Zinc-plated steel
16	Screw	Zinc-plated steel

Dimensions and mass

Valves in Carbon steel with internal thread and handle (Table 2)

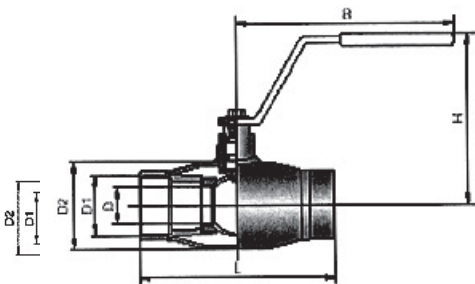

DN	PN	NAF No.	L	D	D1	D2	H	H1	B	Kg
10	40	886650-0010	75	10	R 3/8	33,7	128	49	145	0,5
15	40	886650-0015	85	10	R 1/2	33,7	128	49	145	0,5
20	40	886650-0020	100	15	R 3/4	42,4	133	51	145	0,5
25	40	886650-0025	115	20	R 1	48,3	139	53	145	0,8
32	40	886650-0032	130	25	R 1 1/4	60,3	142	52	145	0,9
40	40	886650-0040	150	32	R 1 1/2	76,1	139	59	190	1,5
50	40	886650-0050	180	40	2	88,9	146	60	190	2,1

Valves in Carbon steel with internal thread/welding and handle (Table 3)

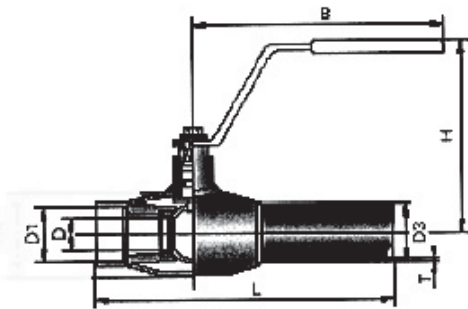

DN	PN	NAF No. mm - pipe	L	D	D1	D2	D3	H	H1	B	T	Kg
10	40	886653-0010	153	10	R 3/8	33,7	17,2	128	52	145	2	0,5
15	40	886653-0015	158	10	R 1/2	33,7	21,3	128	52	145	2	0,5
20	40	886653-0020	168	15	R 3/4	42,4	26,9	133	53	145	2	0,6
25	40	886653-0025	172	20	R 1	48,3	33,7	139	55	145	2	0,8
32	40	886653-0032	195	25	R 1 1/4	60,3	42,4	142	54	145	2	1
40	40	886653-0040	205	32	R 1 1/2	76,1	48,3	139	62	190	2,5	1,7
50	40	886653-0050	240	40	R 2	88,9	60,3	146	63	190	3	2,2

Dimensions and mass

Valves in Carbon steel with welded ends and handle (Table 4)

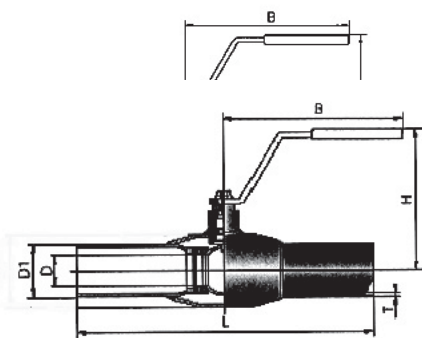

DN	PN	NAF No.	L	D	D1	D2	H	H1	B	Kg
10	40	886651-0010	230	10	17,2	33,7	128	52	145	0,6
15	40	886651-0015	230	10	21,3	33,7	128	52	145	0,6
20	40	886651-0020	230	15	26,9	42,4	133	53	145	0,8
25	40	886651-0025	230	20	33,7	48,3	139	55	145	1
32	40	886651-0032	260	25	42,4	60,3	142	54	145	1,8
40	40	886651-0040	260	32	48,3	76,1	139	62	190	2
50	40	886651-0050	300	40	60,3	88,9	146	63	190	2,7
65	25	886573-0065	300	50	76,1	114,3	170	62	280	4,4
80	25	886573-0080	300	65	88,9	139,7	185	68	280	5,7
100	25	886573-0100	325	80	114,3	168,3	210	101	280	8,4
125	25	886573-0125	325	100	139,7	177,8	253	101	400	13,4
150	25	886573-0150	350	125	168,3	219,3	273	107	600	18

Valves in Carbon steel with welded ends and manual gear (Table 5)

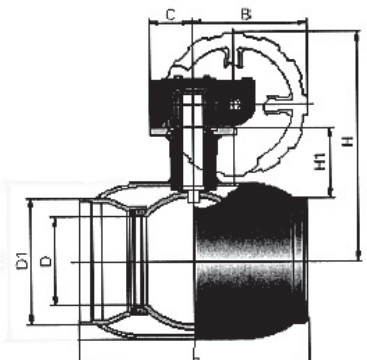

DN	PN	NAF No.	L	D	D1	H	H1	B	C	Kg
125	16	88-284433-DN125	325	100	139,7	309	101	145	50	18
150	16	88-284434-DN150	350	125	168,3	330	107	145	50	23
200	16	88-284436-DN200	390	150	219,1	398	123	196	75	46
250	16	88-284437-DN250	520	200	273,0	451	122	236	100	87
200	16	886371-0200*	390	150	219,1	-	123	-	-	41
250	16	886371-0250*	520	200	273,0	-	122	-	-	82
125	25	88-284473-DN125	325	100	139,7	309	101	145	50	19
150	25	88-284474-DN150	350	125	168,3	330	107	145	50	24
200	25	88-284476-DN200	390	150	219,1	398	123	196	75	48
250	25	88-284477-DN250	520	200	273,0	451	122	236	100	90
200	25	886571-0200*	390	150	219,7	-	123	-	-	43
250	25	886571-0250*	520	200	273,0	-	122	-	-	85

*Excl manual gear

Valves in Carbon steel with flanged ends and handle (Table 6)

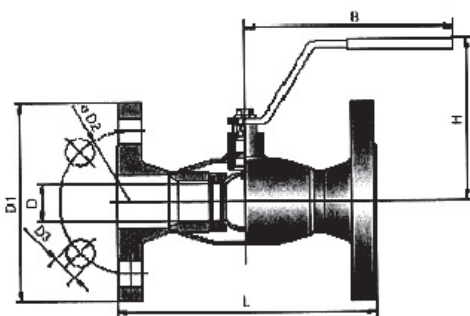

DN	PN	NAF No.	L	D	D3	D2 (hcd)	D1	H	H1	B	Kg
15	40	886602-0015	130	10	14	65	95	98	22	145	1,9
20	40	886602-0020	150	15	14	75	105	103	23	145	2,7
25	40	886602-0025	160	20	14	85	115	118	34	145	3,3
32	40	886602-0032	180	25	18	100	140	121	33	145	5
40	40	886602-0040	200	32	18	110	150	120	43	190	6
50	40	886602-0050	230	40	18	125	165	127	44	190	7,9
65	16	886370-0065	270	50	18	145	185	170	62	280	11
80	16	886370-0080	280	65	18	160	200	185	68	280	14
100	16	886370-0100	300	80	18	180	220	210	101	280	20
125	16	886370-0125	325	100	18	210	250	253	101	400	32
150	16	886370-0150	350	125	22	240	285	273	107	600	50

Valves in Carbon steel with flanged ends and manual gear (Table 7)

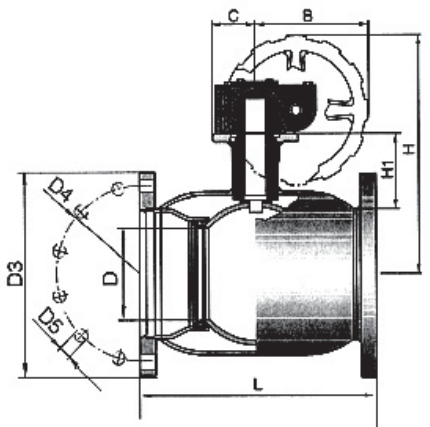

DN	PN	NAF No.	L	D	D3	D4(hcd)	D5	H	H1	B	C	Kg
125	16	88-285533-DN125	325	100	250	210	18	309	101	145	50	29
150	16	88-285534-DN150	350	125	285	240	22	330	107	145	50	36
200	16	88-285536-DN200	400	150	340	295	22	398	123	196	75	65
250	16	88-285537-DN250	530	200	405	355	26	451	122	236	100	113
200	16	886382-0200*	400	150	340	295	22	-	123	-	-	60
250	16	886382-0250*	530	200	405	355	26	-	122	-	-	108

* Excl manual gear

Valve stem dimensions (Table 8)

DN	e	e1	d3	4-k	d4	Actuator flange
10	5,5	9,5	22	7	M5	Option
15	5,5	9,5	22	7	M5	Option
20	5,5	9,5	24	7	M5	Option
25	6	10	24	9	M5	Option
32	6	10	24	9	M5	Option
40	7	11	28	11	M6	Option
50	7	11	28	11	M6	Option
65	13	27	35	14	M12	Option
80	13	27	35	14	M12	Option
100	22,5	23,50	40	16	-	Option
125	29,5	30,50	45	20	-	Option
150	29,5	30,50	45	20	-	Option
200	-	64,10	80	35 Ø	-	ISO F12
250	-	64,10	80	40 Ø	-	ISO F14

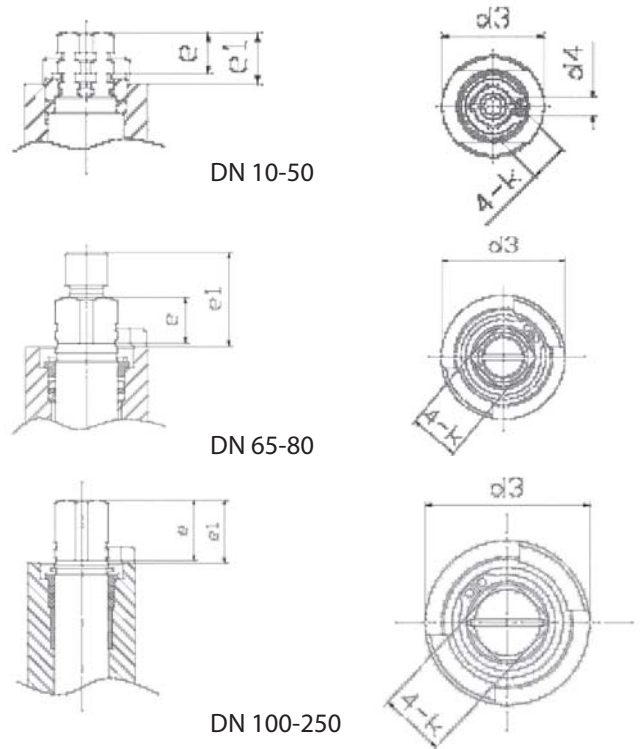

Operating torque (Table 9)

Torque necessary as a function of the differential pressure over the valve.

Diff. tryck bar	Vridmoment i Nm												
	DN												
	10-15	20	25	32	40	50	65	80	100	125	150	200	250
0-7	9	12	16	22	35	45	60	80	110	150	280	460	1120
10	10,2	13,2	17,2	23,2	36,3	46,7	62,7	87	122	185	260	580	1400
13	11,2	14,2	18,2	24,2	37,6	48,4	65,4	93	135	230	430	700	1700
16	12	15	19	25	39	50	68	98	150	270	520	820	2050
19	12,5	15,5	19,8	25,8	40,3	51,6	70,4	103	166	310	600	950	2400
22	12,8	15,8	20,5	26,5	41,6	53,4	72,7	107	183	350	680	1100	2700
25	18	16	21	27	43	55	75	110	200	390	750	1220	3000

The table shows the maximum torque necessary for releasing the ball in closed position (even when the valve has been closed for a long period of time) to be opened 8° — 10°, at which point the differential pressure decreases.

Actuators

Pneumatic and electric actuators

Contact NAF for further information about types and actuator selection procedure.

Ordering example

When placing your order, please specify the NAF part No, DN and description as per the following example: NAF 886650, DN 50, NAF-Navaball ball valve. Please also specify media, pressure and temperature.

Capacity (Table 10)

DN	10	15	20	25	32	40	50	65	80	100	125	150	200	250
Z	0,3	2,6	1,3	0,9	1	0,9	0,9	1,1	0,75	0,9	0,9	0,7	1,35	0,9
Kv	7	5,5	14	26	41	67	105	160	290	420	650	1070	1420	2620

The specified coefficients of resistance are applicable when the valve is fully open. The K_v value is specified in m³/h with cold water at a pressure drop of 1 bar over the valve. The relation between K_v and C_v is as follows:

$$K_v = 0,86 \times C_v \quad C_v = 1,16 \times K_v$$



V&A

www.valve.co.za

Johannesburg Tel : 011-397 2833
 Fax : 011-397 4700
 E-mail : sales.jhb@valve.co.za
 Durban Tel : 031-579 2593
 Fax : 031-579 2562
 E-mail : sales@valve.co.za