

**FLowsERVE**

NAF Control Valves

# ***NAF-Duball Control Valve Package***

## ***Firesafe***

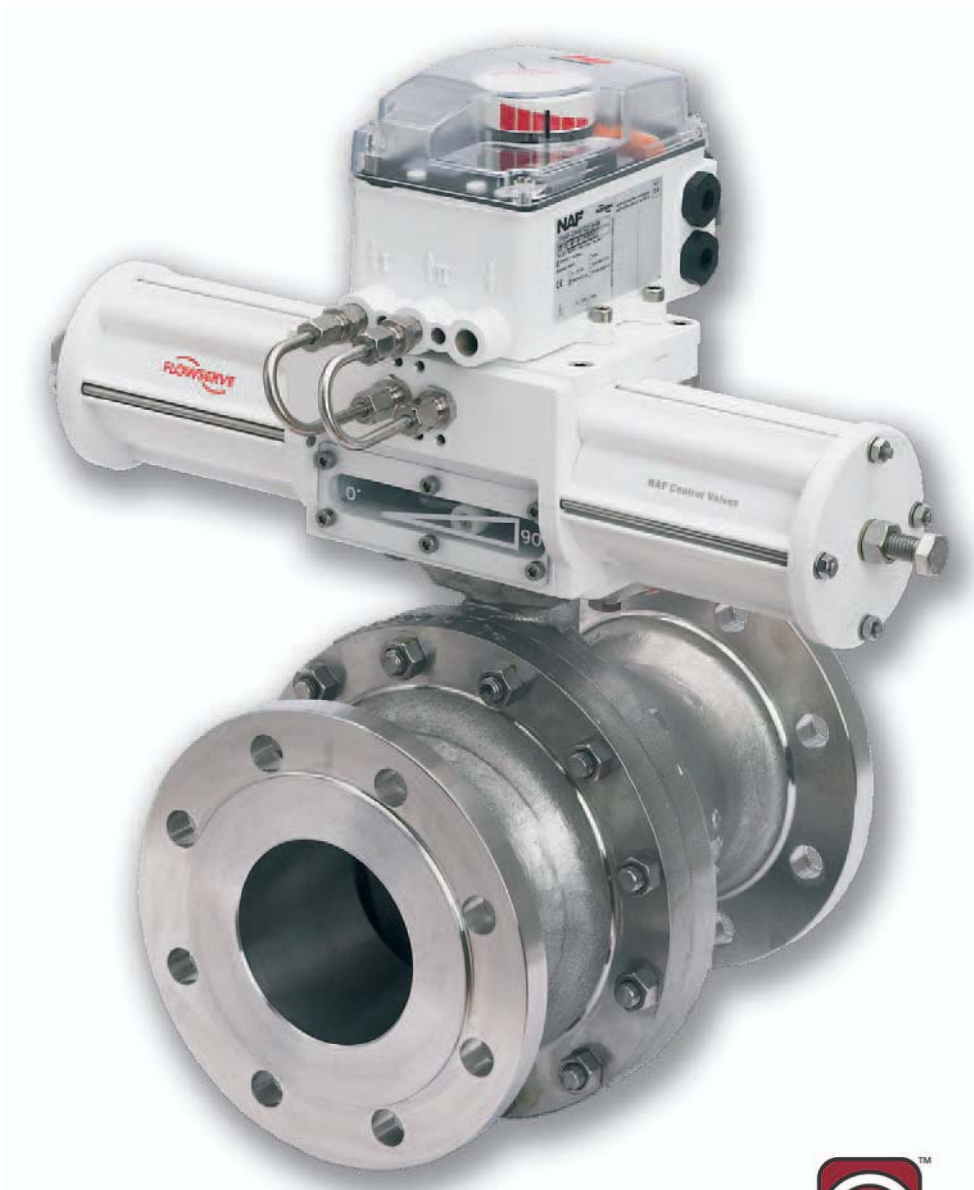

***Experience In Motion***

# Complete solutions for the industry

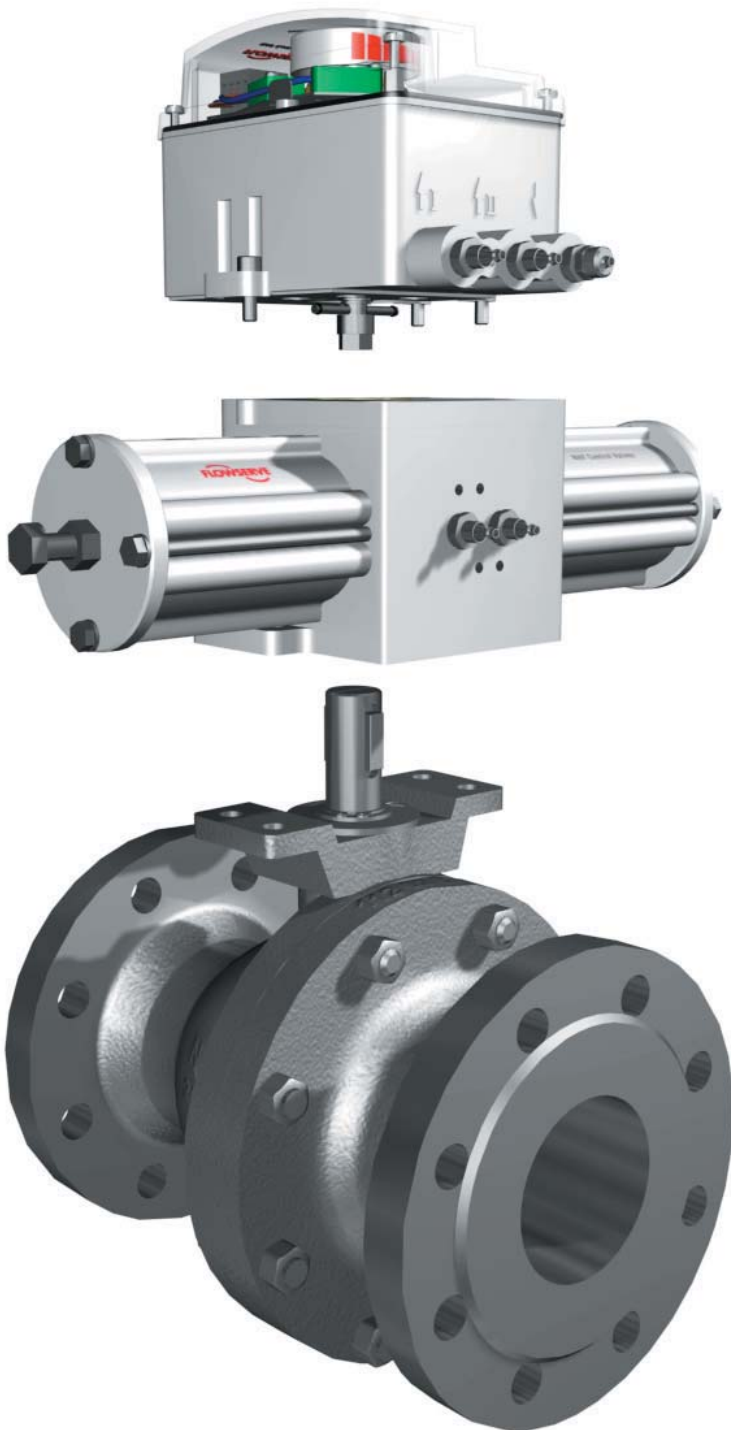

## Communication

### NAF-LinkIT

A high performance intelligent positioner with high air capacity and unique possibilities for diagnostics.

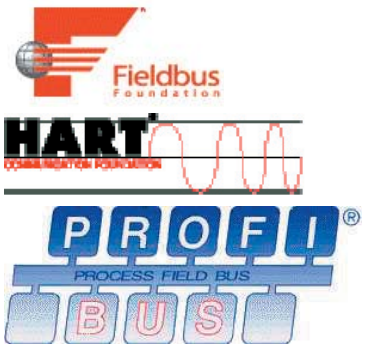

## Actuator

### NAF-Turnex

Heavy-duty actuator for high performance modulating control.

## Valve

### NAF-Duball

Reliable two-piece valve for a tight shut-off. Designed for the most demanding applications.

## Fire safe

Certified according to Firesafe standard B.S. 6755 Part 2 1987.

## ATEX

NAF-Duball is certified according to ATEX 94/9/EC  II 2 G/Dc.

## Materials

Item	Qty	Part	Material
1	1	Body	EN 1.0619/WCB
2	1	Body	EN 1.0619/WCB
3	1	Ball	EN 1.4408/CF8M
4*	2	Seat ring	PTFE carbon reinforced 10%
5	1	Stem assembly	EN 1.4460
6	1	Circlip	Spring steel
7	1	Backing ring	PTFE
8	1	Washer	A4
9	1	Screw	A4
10*	1	Backing ring	PTFE
11*	2	O-ring	FPM
12*	2	Bushing	PTFE carbon reinforced
13*	1	Anti-friction washer	PTFE carbon reinforced
14*	1	Seal ring	PTFE
15	1	Bolt	A4
16	1	Nut	A4
17	1	Stud	A4
18	2	Key	Steel

\* Recommended spare parts

### Seat ring

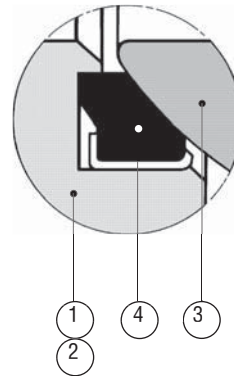

### Stem sealing

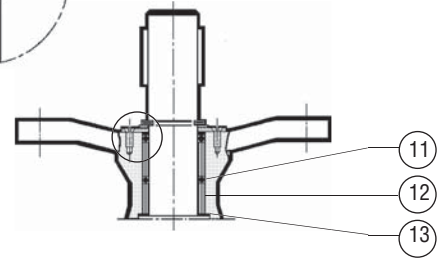
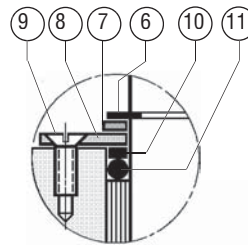

## Technical specification

Material:	CS
Size range:	DN 25—400 (1"—16")
Pressure ratings:	PN 16, 25 and 40 ANSI Class 150—300
Installation method:	Flanges to DIN or ANSI B 16.5
Temperature range:	-30 - 250°C
Test pressure:	1,5xPN with valve open 1,1xPN with valve closed
Sealing class:	PTFE seats ISO 5208 -2 Rate A DIN 3230 BN Leckrate 1

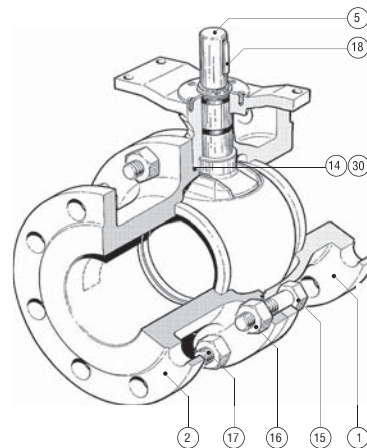

### NAF - The Innovator

NAF started its operations as long ago as 1899. In 1904 the Company delivered its first stainless steel valves to the process industry. And in 1933 it presented the first ball valve to the world. With its unique many-decades' experience, the Company today is one of the most successful in the effective control of demanding flows. Over the course of many years NAF has introduced a range of innovative solutions that meet the stringent requirements of the process industry. In 2002 the Flowserve Corporation acquired NAF. In turn this gave NAF the added resources it needs to invest in the future and continue to lead development.



### High-performance quarter-turn control valves

NAF specializes in quarter-turn, high-performance maintenance-free and intelligent control valve packages with direct mounting and where all parts are modular and designed to give combined optimum performance. They are reliable, easy to service and cost-efficient with extremely long life.

In addition, they are future-safe by the use of modern technology and innovative solutions. The design and high-level quality of the products is a result of over a century's experience of the extreme requirements of the process industry.

### The safe partner

NAF works close to its customers with mutual exchange and respect for each other's knowledge and requirements. The company has always been good at listening to and taking care of its customers' requirements and demands. A good balance between know-how, quality thinking, resources and dependable products, together with a pronounced service-mindedness, makes NAF a secure long-term partner, always placing you as a customer at the center of its focus. And with its global network of experienced and competent representatives local representation is always guaranteed.



# V&A

[www.valve.co.za](http://www.valve.co.za)

Johannesburg Tel : 011-397 2833  
Fax : 011-397 4700  
E-mail : [sales.jhb@valve.co.za](mailto:sales.jhb@valve.co.za)  
Durban Tel : 031-579 2593  
Fax : 031-579 2562  
E-mail : [sales@valve.co.za](mailto:sales@valve.co.za)