

Primary characteristics

There are two versions of the valves, one for steam, air and other gases and the other for liquids but also for gaseous media.

- Orifice and body are designed for high capacity and smooth operation without disc flutter.
- Accurately calculated springs with flat-ground end faces and accurate guiding of the stem ensure that the spring force is transmitted centrally to the disc.
- Nozzle ring for blow down adjustment.

CE-marked according to Pressure Equipment Directive (PED 97/23/EG). For fluid group 2. Module H1, category IV.

Design

The seatings are machined directly on the seat and disc. The valves are fitted with a nozzle ring to adjust the blow down. The safety valves have a lifting lever. The version with lifting lever have screwed BSP male Parallel or flanged connection at the inlet. The outlet has BSP female Parallel threads

Note:

Valves intended for liquids have a closed bonnet and no lifting lever. Each valve is tested before delivery and is adjusted to the required set pressure.

Application

Safety valves NAF 542310 and 542321 are intended for steam, air and other gases. They can be used both for boilers and pipe networks. The capacity table overleaf lists NAF-guarenteed capacities for steam and air. Safety valves NAF 542340 with closed bonnet is intended for liquids and gaseous media. Capacity data for air and water are given in the table overleaf. Max back-pressure for NAF 542340: 0,1 bar. Should not be used for hydrazine-dosed liquids with a pH above 8.



NAF 542310

NAF 542340

Working pressure and temperature according to EN1092-2

NAF 542310 and NAF 542321 max. 11 bar* steam 185°C
 max. 13 bar* air 185°C
 min. 1 bar* 185°C

NAF 542340 max. 11 bar* steam 185°C
 max. 13 bar* air 185°C
 min. 1 bar* 185°C
 max. 13 bar* water 150°C
 min. 1 bar* 150°C

* Gauge pressure

Connections

NAF 542310 and 542340 have screwed BSP male Parallel thread at the inlet and a female thread at the outlet. NAF 542321 has a drilled steel flange acc. to EN1092-1 at the inlet and a female pipe thread at the outlet.

Ordering example:

When ordering, state NAF number, set pressure and temperature as follows:

NAF 542310, DN 40, safety valve, 5 bar gauge saturated steam.

Material specification (Table 1)

Item	Description	Material
1	Bonnet DN 15-25 DN 32-50	Brass EN12240CW614N Gunmetal EN 1982 CC491K
2	Body and seat DN 15-50	Brass SS 5170
3	Disc DN 15-25 DN 32-50	Hot-pressed brass SS 5170 Gunmetal SS 5204
4	Stem	Drawn brass SS 5170
5	Spring	Spring steel SS 1770 or SS 2090
6	Inlet flange (NAF 542321)	Carbon steel EN1.0345

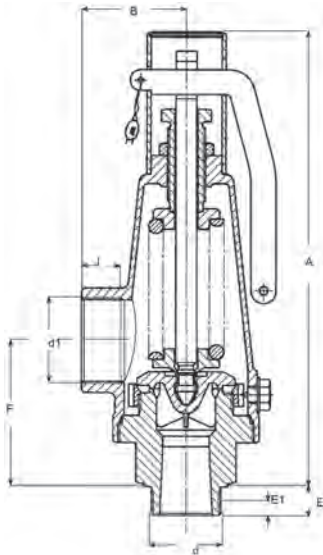
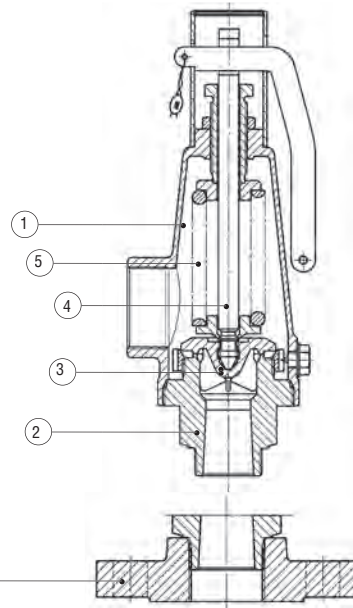

NAF 542310

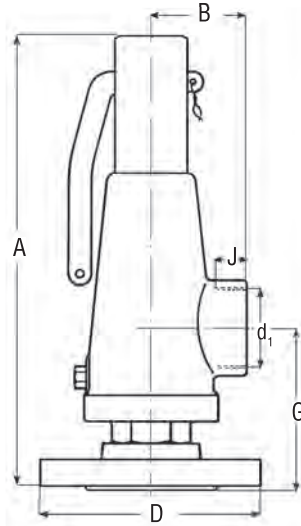

NAF 542321

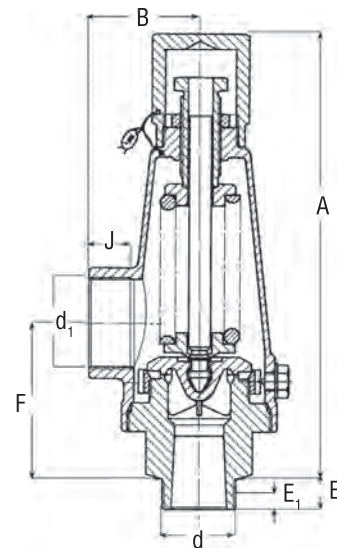

NAF 542340

(Table 2)

NAF No.	DN	Dimensions											Mass, kg				
		Bore diam.	Seat Diam.	D	d	d ₁	E	E ₁	J	B	F	G	A			542310	542321
													542310	542321	542340	542310	542321
542310 542321 542340	15	12	14	95	R 1/2"	R 3/4"	14	8	12	32	40	60	156	176	141	0,8	1,4
	20	17	20	105	R 3/4"	R 1"	21	9	13,5	40	46	70	170	194	155	1,1	1,9
	25	22	28	115	R 1"	R 1 1/4"	24	10	18	50	63	87	215	239	194	2,1	3,2
	32	29	32	140	R 1 1/4"	R 1 1/2"	25	25	23	65	66	92	250	276	230	2,6	4,4
	40	34	38	150	R 1 1/2"	R 2"	25	25	26	70	82	108	293	319	267	4,2	6,2
	50	42	50	165	R 2"	R 2 1/2"	30	30	30	85	93	121	326	354	300	7,3	10,0

Dimensions in mm unless otherwise indicated

Setting ranges of springs in bar gauges ¹⁾ (Table 3)

DN 15	DN 20	DN 25	DN 32	DN 40	DN 50
1,0-2,5	0,5-1,5	1,0-1,5	1,0-1,5	1,0-1,5	1,0-1,5
2,5-4,5	1,5-3,5	1,5-3,5	1,5-3,5	1,5-3,5	1,5-3,5
4,5-8,5	3,5-7,0	3,5-7,5	3,5-7,0	3,5-7,0	3,5-5,5
8,5-13	7,0-13,0	7,5-13,0	7,0-10,0 10,0-13,0	7,0-13,0	5,5-8,0 8,0-10,0 10,0-13,0

¹⁾ If two springs can be used for a pressure range, choose the one with the highest setting range

Capacity (Table 4)

DN	15	20	25	32	40	50	15	20	25	32	40	50	15	20	25	32	40	50
Set Pressure bar *	NAF 542310/21** Capacities in kg/h saturated steam at 10% overpressure						NAF 542310/21/40 Capacities in m ³ /h of free air at 10% overpressure						NAF 542340 Capacities in m ³ /h of water at 10% overpressure					
1	40	60	95	115	155	260	50,4	79	122	152	210	395	1,08	2,10	3,3	6,0	8,4	12,6
2	65	95	145	185	240	410	76,2	126	186	230	321	570	1,50	2,88	4,6	8,4	11,9	17,4
3	80	130	195	240	320	550	103,8	162	250	310	426	768	1,80	3,48	5,7	10,5	14,4	21,6
4	100	155	240	310	405	685	129,6	204	314	389	537	966	2,10	4,02	6,7	12,0	16,2	24,6
5	120	190	290	380	490	820	156,0	246	378	468	660	1158	2,28	4,50	7,5	13,5	18,3	27,6
6	140	215	335	445	570	960	182,4	287	443	546	756	1356	2,52	4,92	8,4	15,0	19,8	30,0
7	160	250	385	500	655	1100	209,4	327	510	630	870	1560	2,70	5,3	9,0	15,9	21,6	33,0
8	180	285	440	575	740	1240	236,4	368	570	708	984	1764	2,88	5,7	9,6	16,8	22,8	34,8
9	200	315	485	630	855	1400	263,4	414	636	786	1098	1962	3,00	6,0	10,2	18,0	24,6	37,2
10	220	350	535	700	920	1530	291	456	708	870	1200	2160	3,18	6,3	10,8	19,2	25,8	39,0
11	240	380	580	770	1000	1660	315	495	774	954	1320	2352	3,36	6,6	11,4	19,8	27,0	40,8
12	-	-	-	-	-	-	342	540	834	1032	1434	2550	3,48	6,9	12,0	21,0	28,2	43,2
13	-	-	-	-	-	-	369	585	900	1110	1548	2760	3,60	7,2	12,6	22,2	28,8	45,0

* Gauge pressure

** According to Swedish boiler code 90 % of guaranteed capacity should be taken as a basis when selecting safety valves for steam

Capacity data for media not listed in the table above will be given on request.

Dimensions in mm unless otherwise indicated



NAF Control Valves
