

Richter Check Valves

CV, BC, SR, GR, RV, PRS

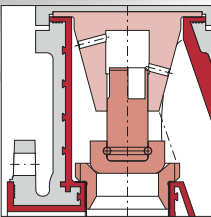

Lining PFA, PTFE, PFA-P
highly permeation resistant,
PFA-L antistatic

Liquids, vapours and gases

Vertical, inclined or
horizontal installation



Richter check valves

They prevent from back-flow of liquids, gases and vapours in pipelines.

They are installed

- e.g. in the discharge line, directly downstream of the pump, to prevent the siphoning of the pump or pump rotation in the opposite direction as a result of back-flowing liquids
- when vessels have to be vented/aerated within approximate setting ranges.

Richter check valves are designed

- for media where stainless steel does not offer lasting corrosion resistance
- as an alternative to valves made of exotic expensive metals (Hastelloy, Monel, tantalum etc.)
- for pure and slightly solids-laden media
- for metal-reactive media, e.g. H₂O₂
- for pure media where good cleaning possibilities and anti-adhesive surfaces are important.

Operating range:

Depending on design and material

- from -60 to +180 °C (-75 to 360 °F)
- from vacuum up to 16 bar (235 psi)

Installation and connecting dimensions

- **ISO/DIN:** face-to-face lengths DIN EN 588-1, basic series 1 (ISO 5752, basic series 1).
- Flange connecting dimensions: DIN EN 1092-2, shape B (ISO 7005-2, type B), on request drilled to ANSI 150
- **ASME (ANSI):** face-to-face lengths Peabody-Dore (BC/BCV series) and ASME (ANSI) B16.10/1/7 Cl. 150 (GR series). Flanges to ASME (ANSI) B16.5/Cl. 150. **ASME (ANSI) Cl. 300** for GR series on request.

Series selection

The operating conditions are so varied that the Richter range contains a large number of check valves:

Series selection	CV	CVV	BC	BCV	SR	SR-B	SRV	SRV-B	SRZ-V	GR	RV
ISO face-to-face	•	•			•	•	•	•	•	•	•
Peabody-Dore/ASME (ANSI) face-to-face			•	•						•	
Gas-tight in seat						•		•	•	•	•
Seat or seat seal replaceable						•		•	•	•	•
Horizontal installation	•	•	•	•	•	•	•	•	•	•	
Vertical installation	•	•	•	•	•	•	•	•	•		•
Inclined installation*	•	•	•	•	•	•	•	•			
Operating pressure > 3 bar (43.5 psi)	•	•	•		•	•			•	•	•
Vacuum-tight	•	•	•	•	•	•	•	•	•	•	•
Operating temperature > 100 °C (210 °F)	•		•		•	•			•	•	•
Operating temperature < -10 °C (-15 °F)	•	•	•	•	•		•			•	•
Integrated sight glass function					•	•	•	•	•		
Top-entry design										•	

* Guidance in centre under ball

Product features

- ① **Lining virgin pure PFA or PTFE**
 - Suitable for corrosive, hazardous, pure, hot and highly permeating media
 - Thick-walled, high permeation resistance
 - Vacuum-resistant anchoring
 - Lining optionally antistatic or highly permeation-resistant PFA-P
- ② **Shell made of ductile cast iron EN-JS 1049 (ASTM A395)** absorbs system and pipe forces
- ③ **Shut-off elements:** solid and hollow balls as well as solid and hollow plugs made of PTFE. For special cases made of stainless steel, Hastelloy etc.
 - Gas-tight sealing: series SR-B, SRV-B and SRZ-V optionally with soft-sealing fluorocautchouc seat sealing.
 - Series GR and RV generally gas-tight sealing.
- ④ **Horizontal, inclined or vertical installation**
- ⑤ **External corrosion protection** Epoxy coating, nuts and bolts of stainless steel.
- ⑥ **Identification** DIN EN 19, ASME (ANSI) B16.34
- ⑦ **PED Pressure Equipment Directive** The valves are suitable for liquids, vapours, gases of group 1.

CV, CVV (ISO) and BC, BCV (ASME/ANSI) series

Installation: horizontal, inclined, vertical pipe

- CV, BC series: with solid ball
- CVV, BCV series: with hollow ball
- Tightness: DIN EN 12266-1, leakage rate D, test medium gas

These ball check valves have a hydraulically optimised design. The lining thickness of 4 to 5 mm offers very high permeation resistance.

The CV and BC series with a solid ball seal against a falling or back-flowing liquid.

The CVV and BCV versions with a hollow ball can also be used for low opening differential pressures. If the installation position is reversed, CVV and BCV can also work as **vacuum check and aeration valves**. When installed vertically, the ball then floats on the rising liquid and seals upwards into the seat.

When installed horizontally, a minimum differential pressure of 1 bar (14.5 psi) – with a hollow ball 0.5 bar (7.25 psi) – is necessary so that the ball is pressed into the seat.

GR series

Installation: horizontal pipe

- Only with solid plug
- Tightness: gas-tight to DIN EN 12266-1, leakage rate A, test medium gas

GR check valves are designed as plug valves and intended for horizontal installation. Seat and plug are exchangeable.

Thanks to the top-entry design, the valve can be opened from the top and serviced.

Lining thickness: 5-6 mm, DN 15+20 (1/2 + 3/4") 3.5-4 mm.

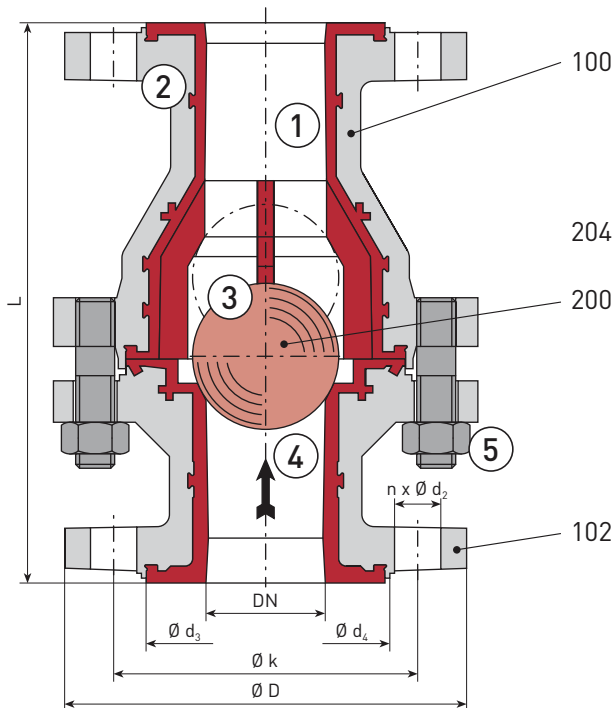

Fig.: CV, BC series, vertical installation, sealing against falling liquid.

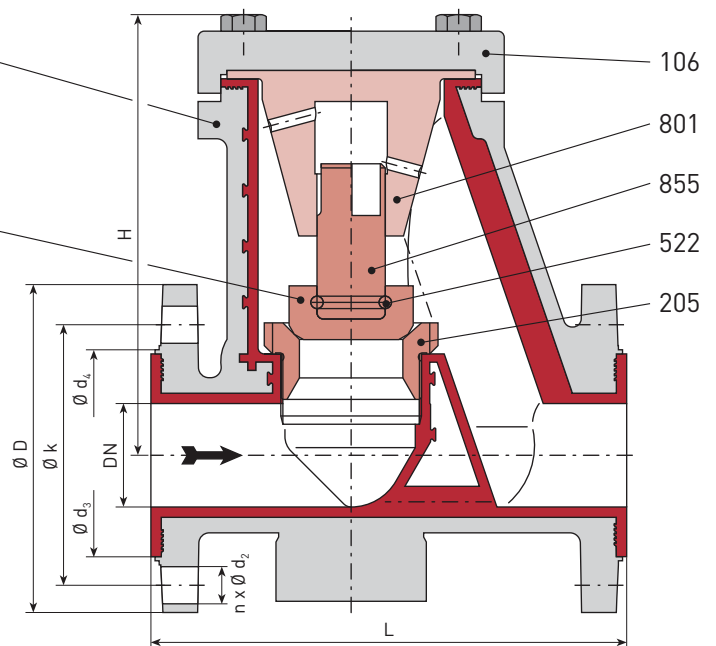

Fig.: GR series, horizontal installation, sealing against back-flowing liquids, vapours, gases

SR, SRV, SR-B, SRV-B and SRZ-V series with integrated sight glass

Installation: horizontal, inclined, vertical (SRZ-V, only vertical) pipe

- SR series with solid ball
- SRV series with hollow ball
- SR-B series with solid ball and soft-sealing seat
- SRV-B with hollow ball and soft-sealing seat
- SRZ-V series with hollow plug and soft-sealing seat

Tightness:

- SR and SRV: DIN EN 12266-1, leakage rate D, test medium gas
- SR-B, SRV-B, SRZ-V: gas-tight to DIN EN 12266-1, leakage rate A, test medium gas

These series make it possible to observe the function of the check valve through thick sight glasses made of borosilicate glass to DIN 7080.

The functions of a straight-through sight glass are fulfilled.

The **solid ball SR and SR-B** versions seal against a **falling or back-flowing liquid**.

The SRV and SRV-B versions with **hollow balls** can also be used for **low opening differential pressures**. With reversed installation position, SRV and SRV-B also function as **vacuum check and aeration valves**.

The ball then floats on the rising liquid and seals upwards into the seat.

When installed horizontally, a minimum differential pressure of 1 bar (14.5 psi) – with a hollow ball 0.5 bar (7.25 psi) – is necessary to press the ball into the seat.

The **hollow plug version SRZ-V** functions in the same way as SRV and SRV-B but for a **much larger pressure/temperature range**, see diagram on page 5.

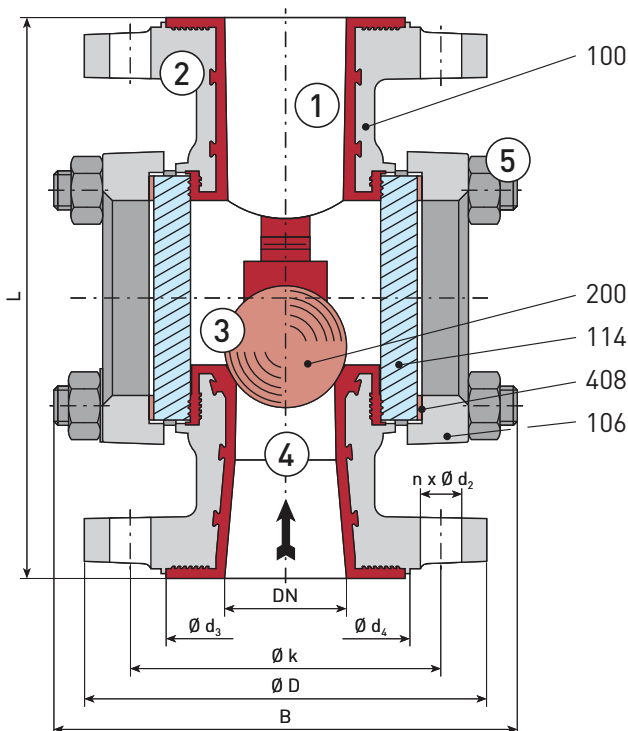

Fig.: SR series, vertical installation, sealing against falling liquid, without seat seal

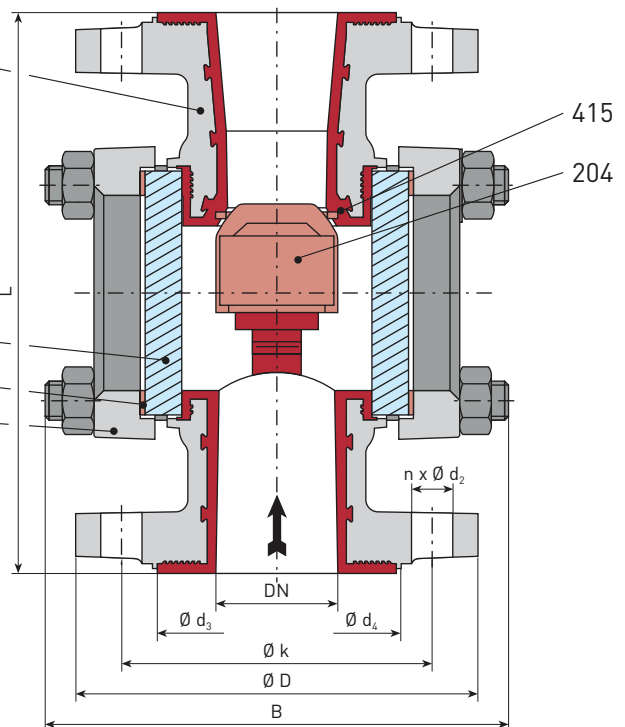

Fig.: SRZ-V series, vertical installation, sealing against rising liquids, with hollow plug and soft-sealing seat seal

Materials, dimensions, weights, pressure/temperature diagram

Components and materials

Item	Designation	Materials
100	Body and body end piece	Shell
102		Ductile cast iron EN-JS 1049 (ASTM A395), GR series optionally GS-C25 (1.0619)
		Lining
106	Cover	Ductile cast iron EN-JS 1049 (ASTM A395), GR series optionally GS-C25 (1.0619)
114	Sight glass pane	Borosilicate glass (e.g. Maxos®)
200	Ball	PTFE ¹⁾ , optionally stainless steel, Hastelloy etc.
204	Plug	Modified PTFE ¹⁾ (TFM-PTFE)
205	Seat	Modified PTFE ¹⁾ (TFM-PTFE)
408	Flat gasket	Aramide
415	Seat seal (optional for SR-B, SRV-B, SRZ-V)	FFKM (e.g. Kalrez®), FKM (e.g. Viton®) ²⁾
522	Round cord	PTFE
801	Guide	Modified PTFE ¹⁾ (TFM-PTFE)
855	Stem	Modified PTFE ¹⁾ (TFM-PTFE)
w/o No.	Screws, nuts	Stainless steel

¹⁾ for lining PFA conductive: PTFE/carbon ²⁾ SRZ-V only with FFKM

Installation and connecting dimensions: CV, CVV, GR, SR, SR-B, SRV, SRV-B, SRZ-V series to ISO 7005-2 PN 16

DN ¹⁾ (mm)	DN ¹⁾ (inch)	L	D	k	d ₃	d ₄	n x d ₂	a
15	1/2"	130	95	65	41	45	4 x 14	-
20	3/4"	150	105	75	54	58	4 x 14	-
25	1"	160	115	85	64	68	4 x 14	48
40	1 1/2"	200	150	110	84	88	4 x 19	65
50	2"	230	165	125	98	102	4 x 19	80
65	2 1/2"	290	185	145	118	122	4 x 19	80
80	3"	310	200	160	134	138	8 x 19	100
100	4"	350	220	180	154	158	8 x 19	125
150*	6"*	394	279	241.5	-	-	8 x 22	-

* DN 150 (6") from BC/BCV series, face-to-face not to ISO/DIN, 100 mm (4") bore

Pressure/vacuum/temperature range

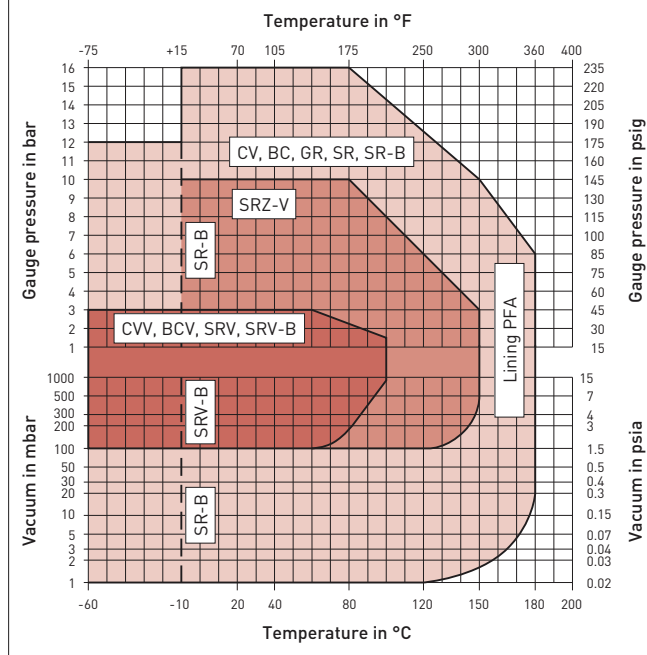

Installation and connecting dimensions: BC, BCV, GR series to ASME (ANSI) Cl. 150 (ISO 7005-2 PN20) and Peabody-Dore.

Series GR to ASME (ANSI) Cl. 300 on request

DN (mm)	DN (inch)	L	D	k	d ₃	d ₄ ⁶⁾	n x d ₂	Series					
								BC, BCV	GR	BC, BCV	GR	BC, BCV, GR	BC, BCV, GR
15	1/2"	130 ¹⁾	130	95	105	60.5	50	54	2)				
20	3/4"	150 ¹⁾	150	105	105	70.0	50	54	4 x 16				
25	1"	152	184	108	110	79.5	51 ³⁾	58 ⁴⁾	4 x 16				
40	1 1/2"	178	222	127	130	98.5	73	77	4 x 16				
50	2"	178	254	152	155	120.5	92	96	4 x 18				
80	3"	203	298	190	190	152.5	127	130	4 x 18				
100	4"	267	353	228	230	190.5	157	160	8 x 18				
150	6" ⁵⁾	394	-	279	-	241.5	-	-	8 x 22				

¹⁾ not to Peabody-Dore

²⁾ tapped bore 4 x 1/2" - 13 UNC

³⁾ GR series: 58 mm

⁴⁾ plastic sealing strip

⁵⁾ passage 4"

⁶⁾ BC/BCV without metallic sealing strip

Nominal sizes, lining materials, k_v (Cv) values and weights

DN (mm)	DIN/ISO series						
	CV, CVV series		SR, SR-B, SRV SRV-B, SRZ-V ⁴⁾ series			GR series	
	Lining ¹⁾²⁾	k _v ³⁾ kg	Lining ¹⁾²⁾	k _v ³⁾	kg	Lining ¹⁾²⁾	k _v ³⁾ kg
15	PFA PFA-L PFA-P	8.5 3.2	-	-	-	PFA PFA-L PFA-P	3.5 5.2
20	PFA PFA-P	16 3.8	-	-	-	PFA PFA-L PFA-P	3.5 5.5
25	PFA PFA-L PFA-P	27 5.2	PFA PFA-L PFA-P	15 (SRZ-V: 10)	6.2	PFA PFA-L PFA-P	13 9.3
40	PFA PFA-L PFA-P	97 9.1	PFA PFA-L PFA-P	35	8.9	PFA PFA-L PFA-P	28 13.2
50	PFA PFA-L PFA-P	122 12.6	PFA PFA-L PFA-P	50 (SRZ-V: 35)	14.5	PFA PFA-L PFA-P	40 17
65	PFA PFA-P	57 15	-	-	-	PFA PFA-L PFA-P	46 18
80	PFA PFA-L PFA-P	300 25	PFA PFA-L PFA-P	125	25	PFA PFA-P	110 38
100	PFA PFA-L PFA-P	410 40	PFA PFA-L PFA-P	170	37	PFA PFA-P	135 43
150	PFA PFA-L PFA-P from BC/BCV series	360 47	-	-	-	-	-

¹⁾ PFA-L = PFA conductive (antistatic)

²⁾ PFA-P highly permeation resistant

³⁾ k_v in m³/h (water 20 °C, 68 °F). Conversion to Cv = k_v x 1.165 (USgpm) or Cv = k_v x 0.971 (IMPgpm)

⁴⁾ SRZ-V: only DN 25+50 (1+2")

DN (inch)	ASME (ANSI) series			
	BC, BCV series		GR series	
	Lining ¹⁾²⁾	k _v ³⁾ kg	Lining ¹⁾²⁾	k _v ³⁾ kg
1/2"	PFA PFA-L PFA-P	7 2.8	PFA PFA-L PFA-P	3.5 5.2
3/4"	PFA PFA-L PFA-P	11 3	PFA PFA-L PFA-P	3.5 5.5
1"	PFA PFA-L PFA-P	22 3.7	PFA PFA-L PFA-P	13 10
1 1/2"	PFA PFA-L PFA-P	63 6.3	PFA PFA-L PFA-P	28 14.5
2"	PFA PFA-L PFA-P	92 8.4	PFA PFA-L PFA-P	40 19
2 1/2"	-	-	-	-
3"	PFA PFA-P	200 22	PFA PFA-P	110 37
4"	PFA PFA-L PFA-P	360 35	PFA PFA-P	135 41
6"	PFA PFA-L PFA-P	360 47	-	-

Other Richter check valves

RV series

- Installation: vertical pipe
- DN 150 (6"), face-to-face 240 mm, k_v -value 400 m³/h (1760 USgpm) and DN 200 (8"), 280 mm, 500 m³/h (2200 USgpm)
- Gas-tight to DIN EN 12266-1, leakage rate A, test medium gas
- Body: ductile cast iron EN-JS 1049 (ASTM A395), lining PTFE
- Seat and plug exchangeable
- Flanges ISO 7005-2 PN16, on request drilled to ASME (ANSI) Cl. 150 (ISO 7005-2 PN20)

Details on pressure/temperature range, materials, dimensions, etc. on request

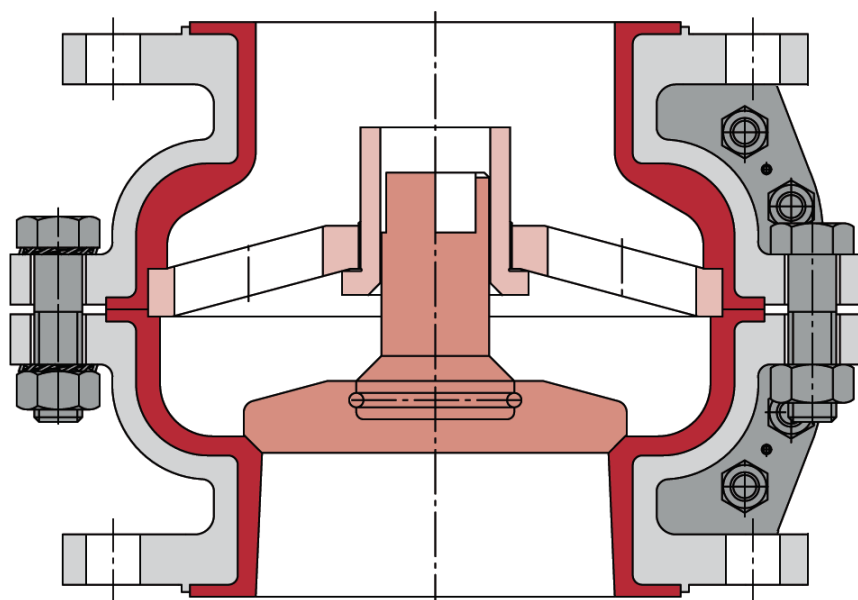

RV series

PRS series

The PRS overflow valve can also be used at low differential pressures to prevent the back-flow of gases, vapours and liquids. The seat/plug combination pre-tensioned with cup springs seals reliably.

- DN 25 (1"), face-to-face 160 mm
- Gas-tight to DIN EN 12266-1, leakage rate A, test medium gas
- Body: ductile cast iron EN-JS 1049 (ASTM A395), lining PTFE
- Plug, guide etc. exchangeable
- Flanges ISO 7005-2 PN16, on request drilled to ASME (ANSI) Cl. 150 (ISO 7005-2 PN20)

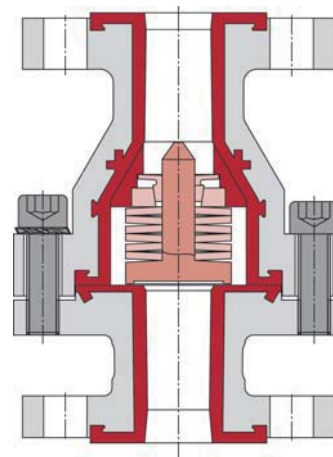

PRS series

Richter = Trademark of Richter Chemie-Technik GmbH

MAXOS[®] = Trademark of Schott AG

Kalrez[®], Viton[®] = Trademark of DuPont

Presented by:



Valve & Automation (Pty) Ltd.

Johannesburg	Durban
Tel: (011) 397 2833	Tel: (031) 579 2593
Fax: (011) 397 4700	Fax: (031) 579 2562
E-Mail: sales.jhb@valve.co.za	E-Mail: sales@valve.co.za

Website: www.valve.co.za



Richter Chemie-Technik GmbH
 Otto-Schott-Str. 2
 D-47906 Kempen, Germany
 Tel. +49(0)21 52/146-0
 Fax +49(0)21 52/146-190
 richter-info @richter-ct.com
 www.richter-ct.com