

Richter Bellows-sealed Globe Control Valves



Corrosion-resistant PFA
ISO/DIN and ANSI/ISA face-to-face
Heavy-duty bellows
Special designs for chlorine
and pure media

 **RICHTER**
Process Pumps & Valves

Richter bellows-sealed globe control valves

Fields of application

Control of corrosive, hazardous, pure and/or slightly solids-laden liquids, vapours and gases in the chemical, pharmaceutical and other industries.

The Richter RSS series is especially suitable

- for media where stainless steel is not sufficiently corrosion-resistant.
- as an alternative to valves made of exotic special metals (Hastelloy, Monel, tantalum etc.).
- for environmentally critical media (German Clean Air Act – „TA-Luft“).
- for metal-reactive media, e.g. H₂O₂.
- for biotechnology and pure media where good cleaning and anti-adhesive surfaces are important (see page 6).
- for highly permeating media (see page 6).

Operating range

- -60 to +200 °C (-75 to 400 °F) operating temperature
- 0.1 mbar vacuum up to 16 (235 psi) bar operating pressure

Design

Bellows-sealed globe control valve. Lined with fluoroplastic. Safety stuffing box as standard. Pneumatic or electric actuation. Also available as manually actuated control or shut-off valve (HVR, HV series).

Control characteristics to DIN EN 60534

Equal percentage, linear, on-off. Rangeability 1:25. Rangeability 1:100 with V-control plug for k_v 0.01 - 1.20 (C_v 0.012 - 1.40), see page 5.

Product features

- Face-to-face lengths ISO 5752-R.1 (DIN EN 558-1 R.1), flanges ISO 7005-2/PN 16, on request drilled to ASME (ANSI) Cl. 150
- Face-to-face lengths ANSI/ISA 75.08.01 Cl. 150, flanges ASME (ANSI) B16.5 Cl. 150 RF
- Face-to-face lengths ANSI/ISA 75.08.01 Cl. 300 for DN 1" to 2", flanges ASME (ANSI) B16.5 Cl. 300 RF
- Comprehensive options package, see pages 5 + 6

Type codes, wetted materials

- Bellows-sealed globe control valve, remote actuation RSS/...

Lining:

- PFA (perfluoroalkoxy) .../F
- Antistatic PFA-L .../F-L
- Highly permeation-resistant PFA-P .../F-P

Identification

to DIN EN 19, ANSI B16.34



Option:
Heavy-duty PTFE bellows
with stainless steel or
PTFE/carbon support rings.

- ① **Thick-walled virgin PFA lining**
 - Optional PFA-L antistatic and PFA-P highly permeation-resistant linings.
 - Lining thickness: 5-6 mm DN 15+20 (1/2" + 3/4"): 3.5-4 mm.
 - Vacuum-proof
- ② **One-piece valve body**
as well as all other pressure-bearing components made of ductile cast iron EN-JS 1049 (ASTM A395), alternatively cast steel 1.0619 (GS-C 25).
 - Absorbs system pressure and pipe forces.
 - Top entry = simple maintenance of bellows, plug and seat.
 - Body heating on request.
- ③ **PTFE bellows**
hermetically seal the product chamber from the atmosphere and protect the valve stem against corrosion. Standard PTFE bellows up to 10 bar operating pressure.

Options (see also page 5):

 - **Heavy-duty PTFE bellows** for highly permeating media, high temperatures and pressures up to 16 bar.
 - **Hastelloy bellows** for special cases, e.g. extreme permeation and pressure/temperature conditions.
- ④ **Safety stuffing box**
Adjustable from outside as a standard feature. Valve design complies with the German Clean Air Act.
- ⑤ **Monitor connection**
as an option, especially in case of critical media.

⑥ Exchangeable valve plug

- Modified pure TFM-PTFE, no fillers.
- Screwed to bellows without play and secured by means of PTFE cord.
- Change in k_{v100}/C_v value by replacing seat/plug.
- Special V-control plug made of TFM-PTFE for minimum k_v -values from 0.01 m³/h (C_v 0.012), see page 5.
- Special U-plug if there is a risk of cavitation.

⑦ Exchangeable seat

- made of modified pure TFM-PTFE, no fillers.

⑧ Easy top entry maintenance

- of the wetted internals: removable valve bonnet

High-quality external corrosion protection:

- Epoxy coating of the valves
- Valve stem and screws made of stainless steel, other materials like Hastelloy etc. optional.

⑨ Actuators and accessories

- Pneumatic or electric actuators
- Positioners, limit switches etc.

All common makes.

⑩ Travel stop

- protects plug and seat against excessively high shut-off forces, installation as per table on page 4 depending on Δp and seat \varnothing .
- With protective rubber bellows.

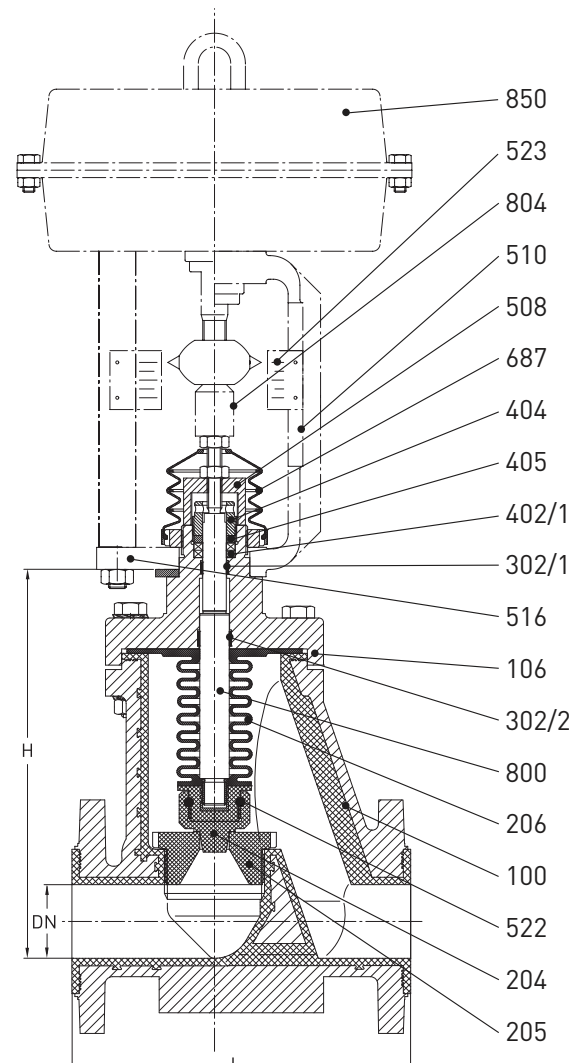
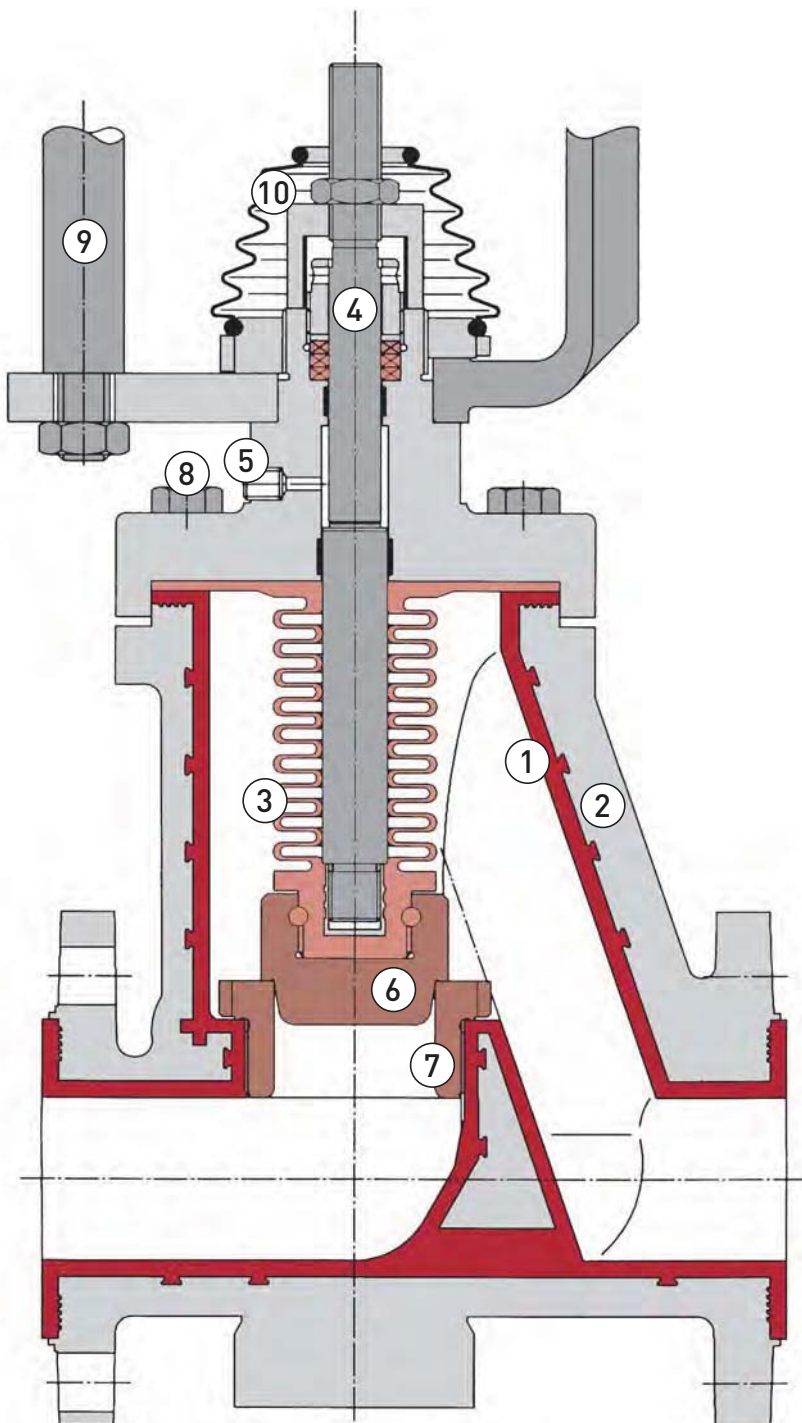

Flow rates k_{v100} (m³/h), Cv (US gpm)

DN DIN/ISO (mm)	ANSI (inch)	k_{v100} Cv	Seat-Ø mm (inch)																																	
			96 (3.8)	80 (3.1)	65 (2.6)	50 (2)	40 (1.6)	30 (1.2)	25 (1)	20 (0.8)	15 (0.6)	8 (0.3)	DN 15+20 (1/2" + 3/4"): Seat ø 8 mm (0.31")					DN 25 (1"): Seat ø 14 mm (0.55")																		
15+20	1/2+3/4	k_{v100} Cv										4	2	0.80	0.50	0.20	0.10	0.05	0.02	0.01	4.7	2.33	0.93	0.58	0.23	0.12	0.06	0.023	0.012							
25	1	k_{v100} Cv										11	7	4	2	1.20	0.80	0.50	0.20	0.10	0.05	0.02	0.01	12.8	8.2	4.7	2.33	1.40	0.93	0.58	0.23	0.12	0.06	0.023	0.012	
40	1 1/2	k_{v100} Cv										28	15	11	7	4								32.6	17.5	12.8	8.2	4.7								
50+65	2	k_{v100} Cv										42	28	15	11	7								48.9	32.6	17.5	12.8	8.2								
80	3	k_{v100} Cv										100*	65	42	28	15								117*	75.7	48.9	32.6	17.5								
100	4	k_{v100} Cv										155*	100*	65	42									180*	117*	75.7	48.9									

* If a U-plug is used, the k_{v100} (Cv) values reduce from 155 m³/h (180 US gpm) to 135 m³/h (157 US gpm) and from 100 m³/h (117 US gpm) to 90 m³/h (105 US gpm).

- Remarks:
- V-control plugs are used for the k_{v100} values 0.01 to 1.2 (Cv 0.012-1.4), see page 5.
 - The next lower k_{v100} (Cv) value can also be attained by using a different plug without changing the seat diameter. This may be important as it is only necessary to replace the plug if the k_{v100} (Cv) value is later changed.
 - Conversion k_{v100} to Cv (US gpm) = $k_{v100} \times 1.165$.

Pressure/temperature range

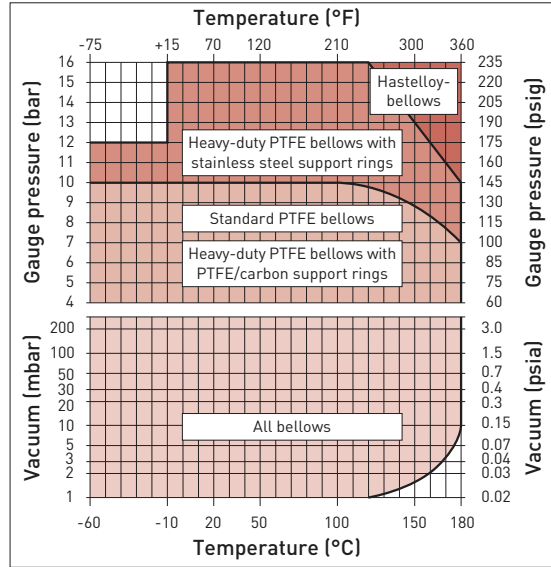

Components and materials

Item	Designation	Material
100	Body	Shell: ductile iron EN-JS 1049 (ASTM A395), optionally cast steel GS-C 25 (1.0619) Lining: PFA, optionally PFA-L antistatic + PFA-P highly permeation-resistant
106	Cover	D.c.i. EN-JS 1049 (ASTM A395)
204	Plug	TFM-PTFE
205	Seat	TFM-PTFE
206	Bellows	PTFE, TFM-PTFE, PTFE/carbon antistatic, Hastelloy. Heavy-duty version: with stainless steel or PTFE/carbon support rings
302/x	Guide ring	
402/1	Packing ring	PTFE
404	Packing nut	Stainless steel
405	Thrust ring	Stainless steel
508	Travel stop*	Stainless steel
510	Bracket	Steel, epoxy-coated
516	Yoke	Ductile cast iron, epoxy-coated
522	Round cord	PTFE
523	Travel indicator	Stainless steel
687	Protect. bellows	Rubber, w/travel stop as option
800	Valve stem	Stainless steel
801	Guide	Stainless steel
804	Coupling	Stainless steel
850	Actuator	
917/1	Screw-in pipe connector**	Stainless steel, optionally hex. head screw plug

* depending on shut-off force
** option. with safety stuffing box, not shown here

Required shut-off forces (N) with seat and plug made of modified TFM-PTFE*

Seat-Ø mm (inch)	bar / psi															
	1/14.5	2/29	3/43.5	4/58	5/72.5	6/87	7/102	8/116	9/131	10/145	11/160	12/174	13/189	14/203	15/218	16/232
8 (0.32)	290	310	330	350	370	390	410	430	450	470	495	510	525	540	555	570
14+15 (0.55+0.6)	330	385	435	490	540	595	645	695	750	800	865	900	935	970	1005	1040
20 (0.8)	390	460	525	595	665	730	800	865	935	1010	1145	1195	1250	1300	1355	1410
25 (1.0)	450	545	640	735	830	925	1020	1115	1205	1305	1475	1550	1625	1705	1780	1855
30 (1.2)	550	680	805	935	1065	1190	1320	1445	1575	1705	1890	1990	2095	2195	2295	2400
40 (1.6)	680	885	1085	1290	1490	1695	1895	2095	2300	2480	2750	2915	3080	3250	3415	3570
50 (2.0)	830	1130	1425	1720	2020	2315	2610	2910	3205	3500	3790	4035	4280	4525	4770	5020
65 (2.6)	1040	1500	1960	2420	2890	3350	3810	4270	4740	5190	5675	6070	6465	6860	7255	7650
80 (3.1)	1300	1970	2630	3300	3960	4630	5300	5960	6630	7305	7945	8525	9105	9685	10265	10850
96 (3.8)	1600	2520	3440	4370	5290	6210	7130	8050	8980	9900	10790	11610	12425	13240	14060	14880

Max. Δp bar/psi, valve in closed position
Standard PTFE bellows (max. oper. pressure 10 bar/145 psi)
Heavy-duty PTFE bellows (max. oper. press. 16 bar/232 psi)**
Hastelloy C-bellows (max. oper. pressure 16 bar/232 psi)

Mechanical travel stop (see shaded cells) has to be provided if
• Δp > 10 bar/145 psi and seat Ø 14-50 mm (0.55"-2")
• Δp > 6 bar/ 87 psi and seat Ø ≥ 65 mm (≥ 2,6")

Attention: If Δp < p₂, then insert p₂ instead of Δp.
* Plugs and seats made of other materials sometimes require higher shut-off forces. Details on request.
** - available for DN 25-100 (1"-4").
Heavy-duty PTFE bellows with PTFE/carbon support rings: max. operating pressure 10 bar/145 psi.
- for DN 25 (1") with 15 mm travel (0.6"). In the case of actuators with a larger travel, the required control curve is achieved by means of positioners.
- Valve opening travel requires higher forces than with standard PTFE bellows:
DN 25 (1") = 900 N, DN 40/50/65 (1 1/2", 2", 2 1/2") = 2000 N, DN 80/100 (3", 4") = 800 N.
Please consider this when sizing the actuator.

Dimensions and weights

Face-to-face lengths ISO 5752 series 1 (DIN EN 588-1 series 1)*, flanges ISO 7005-2/PN16 (DIN EN 1092-2)*

DN (mm)	H (mm)	L (mm)	Weight** approx. kg
15	130	130	6
20	130	130	6
25	185	160	11
40	225	200	16
50	230	230	19
65	230	290	20
80	340	310	39
100	350	350	44

* formerly DIN 3202/F1, 2532/33
** without actuator

Face-to-face lengths ANSI/ISA 75.08.01 Cl. 150+300, flanges ASME (ANSI) B16.5 Cl. 150+300 RF

DN (ZoL)	H (mm)	L Cl. 150 (mm)	L Cl. 300 (mm)	Weight** approx. kg
1/2"	130	130***	-	6
3/4"	130	130***	-	6
1"	185	184	197	12
1 1/2"	225	222	235	17
2"	230	254	267	19
3"	340	298	-	39
4"	350	353	-	44

* DN 1/2": flanges with tapped bore
** without actuator *** not to ANSI/ISA

Richter = WZ Richter Chemie-Technik GmbH

Heavy-duty bellows for DN 25-100 (1"-4")

These bellows were developed for particularly difficult operating conditions:

- **Highly permeating media:**
The wall thickness of 2.5 mm ensures considerably higher resistance to permeation. Also available in modified TFM-PTFE for particularly strong permeation.
- **Higher pressures and temperatures:**
The convolutions of the bellows retain their function even at a pressure of 16 bar (235 psi) and

at elevated temperatures: They are individually supported on the stainless steel support rings (and not on the valve stem!) and thus remain flexible. On request, support rings are also available in PTFE/carbon for an operating pressure of 10 bar (145 psi).

- **For high-purity media:**
Large convolution distances facilitate flushing/sterilisation of the inner valve chamber (see also page 6 „Version for biotechnology/pure media“).

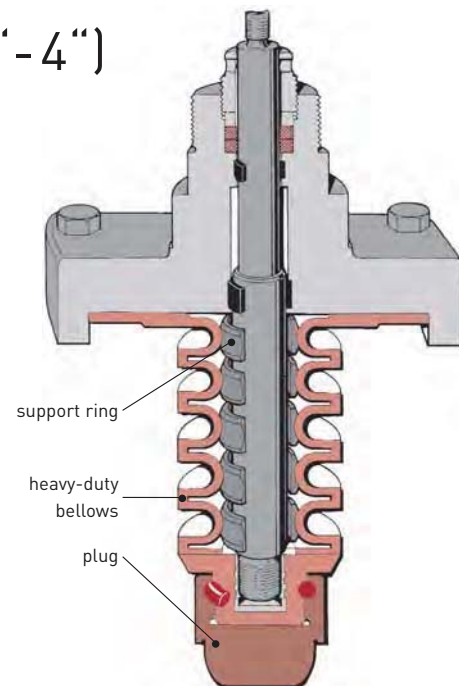

RSS V-plug for small k_v 0.01-1.20 (C_v 0.012-1.4)

The V-plug made of compression-proof and dimensionally stable TFM-PTFE has 1 to 4 grooves, depending on the k_v/C_v value. When the valve opens, the V-grooves offer an expanding opening cross section whilst the plug is always guided in the seat. This ensures high-quality control even at elevated temperatures and differential pressures.

A dynamic sealing lip integrated into the seat limits the flow precisely to the V-grooves, thus preventing undesired leakage. A PTFE cord prevents the plug from unscrewing. Hastelloy or tantalum plug inserts, which were previously used for stability and accuracy reasons, can now be dispensed with.

Customer benefits: Lower costs, shorter delivery times, metal-free, maximum chemical resistance. The V-plugs are the preferred version for RSS valves DN 15-25 (1/2-1") with low k_v/C_v -values.

Operating range

- Up to 16 bar at 180 °C (235 psi at 360 °F)
- Pressure/temperature diagram: see page 4
- Not for highly viscous or solids-containing media

$k_{vs 100}$ -values (m^3/h), C_v -values (USgpm)

DN 15 + 20 (1/2 + 3/4"), seat Ø 8 mm. Travel 15 or 20 mm.

DN 25 (1"), seat Ø 14 mm. Travel 15 or 20 mm.

$k_{v 100}$	0.01	0.02	0.05	0.10	0.20	0.50	0.80	1.20*
C_v	0.012	0.023	0.06	0.12	0.23	0.58	0.93	1.40*

Other sizes and k_v/C_v -values on request.

* only DN 25 (1")

Control characteristics

Quadratic curve, rangeability 1:100

Travel (%)	5	10	20	30	40	50	60	70	80	90	100
Flow rate (%)	1.25	2	5	10	17	26	37	50	64	81	100

Components and material

204 Plug	TFM-PTFE
205 Seat	TFM-PTFE
522 Cord	PTFE

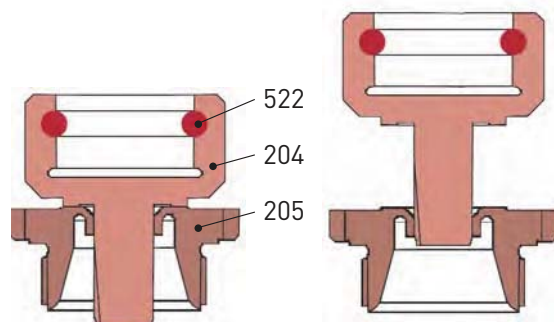
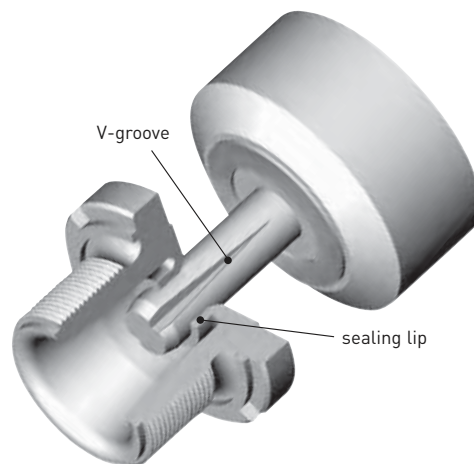

Other options

Version for highly permeating media (e.g. chlorine)

The special bush ① – material e.g. Hastelloy C – protects the cover flange in the valve stem area against corrosive attack by permeating media. The valve stem – also e.g. Hastelloy C – remains moveable. Bellows: TFM-PTFE heavy-duty bellows with PTFE/carbon or Hastelloy support rings or bellows made of Hastelloy C ②. The thick-walled seamless body lining provides outstanding protection against permeation. Optionally, special highly permeation-resistant Richter PFA-P lining.

Version for „biotechnology/pure media“

Pharmaceutical, fine and semi-conductor chemicals, fermentation etc., suitable for CIP and SIP!

In the segment of PFA lined globe control valves this time-tested version is unique:

- Free from cavities.
- Anti-adhesive PFA body lining without fillers with seamlessly integrated seat.
- One-piece PTFE bellows/plug design ① with large convolution distances, easy to clean ②, DN 15+20 (1/2"+3/4") with standard bellows.
- On request, special „high-purity media production process“ and FDA conformity certificate.

Operation close to cavitation

This special U-plug (U = circumferential guiding) is recommended, when cavitation might occur with DN 80 and 100 (3"+4"). It reliably overcomes the higher loads by dividing the medium flow and through the permanent guide in the valve seat. Universal for all RSS bellows versions.

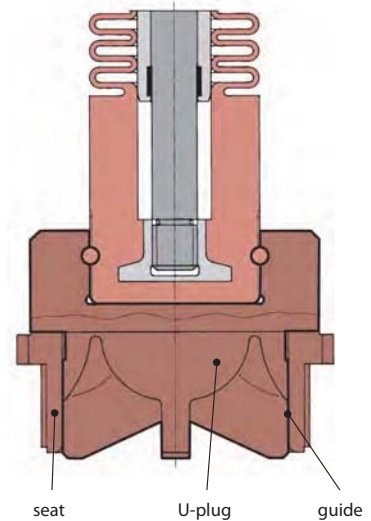

Control ball valve KNR

Compact valve with special control ball for
 k_v 0.8-400 (Cv 0.93-465 US gpm).
 DN 15-200 (1/2"-8"), face-to-face lengths and flanges to ISO/DIN and ASME/ANSI.
 See separate publication.

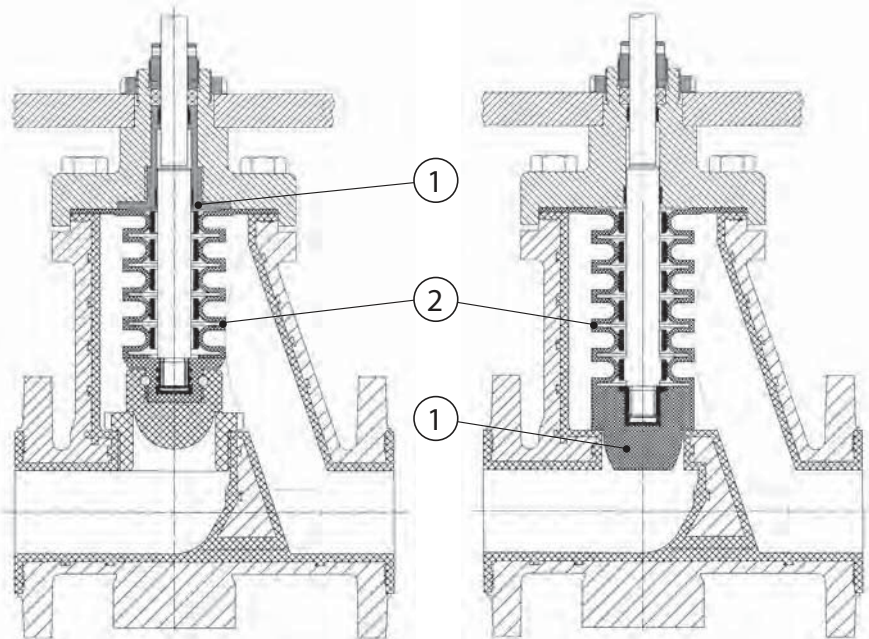

Presented by:



Valve & Automation (Pty) Ltd.

Johannesburg

Tel: (011) 397 2833

Fax: (011) 397 4700

E-Mail: sales.jhb@valve.co.za

Durban

Tel: (031) 579 2593

Fax: (031) 579 2562

E-Mail: sales@valve.co.za

Website: www.valve.co.za



RICHTER
 Process Pumps & Valves

Richter Chemie-Technik GmbH

Otto-Schott-Str. 2

D-47906 Kempen, Germany

Tel. +49 (0) 21 52 / 146-0

Fax +49 (0) 21 52 / 146-190

richter-info @richter-ct.com

www.richter-ct.com